

VENTING AND RAPID RECOMPRESSION INCREASE SURVIVAL AND  
IMPROVE RECOVERY FOR RED SNAPPER WITH BAROTRAUMA

Prepared by

Karen L. Drumhiller  
August 2012

A Thesis Submitted  
In Partial Fulfillment of the  
Requirements for the Degree of

MASTER OF SCIENCE

The Graduate Marine Biology Program  
Department of Life Sciences  
Texas A&M University-Corpus Christi

APPROVED: \_\_\_\_\_ Date: \_\_\_\_\_  
Dr. Gregory W. Stunz, Chair

\_\_\_\_\_ Date: \_\_\_\_\_  
Dr. Matthew Johnson, Co-Chair

\_\_\_\_\_ Date: \_\_\_\_\_  
Dr. Lee Smee, Committee Member

\_\_\_\_\_ Date: \_\_\_\_\_  
Dr. Joe Fox, Chair  
Department of Life Sciences

\_\_\_\_\_ Date: \_\_\_\_\_  
Dr. Frank Pezold, Dean  
College of Science and Engineering

Format: *Transactions of the American Fisheries Society*

## ABSTRACT

Red Snapper, *Lutjanus campechanus*, are the most economically important reef fish in the Gulf of Mexico. Population assessments that began in the mid-1980's found red snapper to be severely overfished and lead to extensive regulations and harvest restrictions. As a result of these regulations many fish that are captured must be released and are known as regulatory discards. Red snapper live deep in the water column and when captured and rapidly brought to the surface they often suffer pressure-related injuries collectively known as barotrauma. These injuries include a distended abdomen and stomach eversion from the buccal cavity. High mortality of discards due to barotrauma injuries impedes recovery of the fishery. The purpose of this study was to evaluate the efficacy of two techniques designed to minimize barotrauma-related mortality: venting and rapid recompression. In laboratory experiments using hyperbaric chambers, I assessed sublethal effects of barotrauma and subsequent survival rates of red snapper after single and multiple simulated capture events from pressures corresponding to 30 and 60 m. I evaluated the use of rapid recompression and venting to increase survival and improve recovery indices, including the ability to evade a simulated predator. A condition index of impairment, the barotrauma reflex (BtR) score, was used to assess sublethal external barotrauma injuries, reflex responses, and behavioral responses. Greater capture depths resulted in higher BtR scores (more impairment). Non-vented fish had higher BtR scores than vented fish after both single and multiple decompression events. All fish in vented treatments from 30 and 60 m depths had 100% survival after a single capture event. Non-vented fish had 67% survival after decompression from 30 m and 17% survival from 60 m. Behaviorally, non-vented fish

showed greater difficulty achieving an upright orientation upon release and less ability to evade a simulated predator than vented fish. Rapid recompression also greatly improved survival compared to surface-released fish with 96% of all rapidly recompressed fish surviving. These results clearly show that venting or rapid recompression can be effective tools for alleviating barotrauma symptoms, improving predator evasion after a catch-and-release event, and increasing survival. Fisheries managers should encourage the use of either of these two techniques to aid in the recovery of this important fishery.

## TABLE OF CONTENTS

<i>ABSTRACT</i> .....	i
<i>TABLE OF CONTENTS</i> .....	iii
<i>LIST OF TABLES</i> .....	iv
<i>LIST OF FIGURES</i> .....	v
<i>ACKNOWLEDGEMENTS</i> .....	vi
<i>INTRODUCTION</i> .....	1
<i>METHODS</i> .....	10
Fish collection and maintenance.....	10
Hyperbaric chambers .....	11
General Experimental design.....	11
Acclimation to pressure and decompression .....	15
Assessment of barotrauma injuries and reflex responses .....	16
Barotrauma relief procedures and behavior tests.....	17
Data analysis .....	20
<i>RESULTS</i> .....	21
<b>Sublethal effects of barotrauma/ BtR scores</b> .....	21
<i>Percent occurrence of sublethal indices</i> .....	21
<i>Effects of venting at surface pressure</i> .....	23
<i>Depth effects on sublethal impairment</i> .....	33
<b>Survival</b> .....	34
<i>Survival rates after one decompression event</i> .....	34
<i>Survival rates after multiple decompression events</i> .....	37
<i>DISCUSSION</i> .....	40
<b>Survival rates and sublethal effects from barotrauma</b> .....	40
<i>Venting</i> .....	40
<i>Rapid recompression</i> .....	43
<i>Predation</i> .....	44
<i>Multiple decompression events</i> .....	45
<i>Effects of depth</i> .....	46
<i>Immediate and long term survival</i> .....	47
<b>Differences in laboratory and field conditions</b> .....	48
<b>Management implications and conclusions</b> .....	50
<i>LITERATURE CITED</i> .....	54

## LIST OF TABLES

Table 1. The experimental design for conducting barotrauma studies on red snapper.....	15
Table 2. Percent occurrence of red snapper exhibiting barotrauma symptoms and impaired reflex responses after decompression from depths of 0, 30 or 60m.....	22
Table 3. Percent occurrence of red snapper exhibiting impaired behavioral responses after decompression from depth and release at surface (ambient) pressure in each venting and depth treatment combination.....	26
Table 4. Relative impairment, as shown by mean barotrauma reflex (BtR) scores ( $\pm$ SE), of red snapper that have been decompressed from 0, 30, or 60 m depths (A) one time or (B) three times and then vented and surface released (VSR) into an open holding tank or non-vented and surface released (NSR).....	28
Table 5. Results of a two-factor repeated measures analysis of variance for the effects of depth and venting on red snapper barotrauma reflex (BtR) score over three decompression events.....	30
Table 6. Results of a repeated measures analysis of variance for the effects of (A) depth and (B) venting on red snapper barotrauma reflex (BtR) score over three decompression events.....	30
Table 7. Relative impairment, as shown by mean barotrauma reflex (BtR) scores ( $\pm$ SE), of red snapper that have been decompressed from 0, 30, or 60 m depths and then vented and surface released (VSR) into an open holding tank or non-vented and surface released (NSR).....	32
Table 8. Effects of depth and release type on survival of red snapper subject to rapid decompression using exact logistic regression.....	36
Table 9. Percent survival of red snapper decompressed from depth one time, released at surface (ambient) pressure or rapidly recompressed, and vented or not vented.....	36

## LIST OF FIGURES

Figure 1. Schematic drawing of the flow-through hyperbaric chamber used to simulate the pressure changes experienced by red snapper during capture events from 30 and 60 m depths.....	13
Figure 2. Photograph of a hyperbaric chamber used to simulate the pressure changes experienced by red snapper during hook-and-line capture events.....	14
Figure 3. Relative impairment, as shown by mean barotrauma reflex (BtR) scores ( $\pm$ SE), of red snapper that have been decompressed from depth (A) one time or (B) three times and then vented and surface released (Vent SR) into an open holding tank or non-vented and surface released (Non-Vent SR).....	25
Figure 4. Relative impairment, as shown by mean barotrauma reflex (BtR) scores ( $\pm$ SE), among treatments of red snapper that have been decompressed from 0, 30 or 60 m depths (A) one time or (B) three times and then vented and surface released (VSR) into an open holding tank or non-vented and surface released (NSR).....	27
Figure 5. Relative impairment, as shown by mean barotrauma reflex (BtR) scores ( $\pm$ SE), of red snapper that have undergone three decompression events from 0, 30 or 60 m depths and then were (A) vented and surface released (VSR) into a holding tank or (B) non-vented and surface released (NSR).....	31
Figure 6 Relative impairment from decompression injuries, as shown by depth-barotrauma reflex (depth-BtR) scores ( $\pm$ SE), of red snapper that have been decompressed from 0, 30 or 60 m depths.....	33
Figure 7. Percent survival of red snapper decompressed from depth and then vented and rapidly recompressed (VRR), vented and surface released (VSR) into an open holding tank, non-vented and rapidly recompressed (NRR) or non-vented and surface released (NSR).....	35
Figure 8. Percent survival of red snapper by treatment group after three decompression events.....	38
Figure 9. Percent survival of red snapper by treatment group after each of three decompression events.....	39

## ACKNOWLEDGEMENTS

I would like to thank my Advisor and Committee Chair, Dr. Greg Stunz for all his help and guidance in making this project a reality and my Co-Chair Dr. Matthew Johnson for helping get this project created, helping me build the chamber set-up and for all his help along the way. My committee member Dr. Lee Smee has been a great asset throughout my time in TAMUCC and his help writing the initial pre-version of this paper in his class was invaluable.

Thank you to my funding sources: NOAA MARFIN, TAMU-CC, the Harte Research Institute and Texas American Fisheries Society.

I am overwhelmingly grateful to everyone at Texas AgriLife in Port Aransas, especially Dr. Addison Lawrence for access to the facility. Everyone there was awesome, and there is no way I could have done this project without you. Thanks to Brinson, Dan, Jack, Jeff K. (At FAML), Josh, Patty, Roger, Susmita, Terrance, Wendy, Woody, and Sam the cat! (for scaring away the cockroaches at night)

Thanks to Mo Azul Sport Fishing and Fisherman's Wharf in Port Aransas for their assistance in collecting fish.

Thank you to Dr. Sandra Diamond for the use of her hyperbaric chambers and for her suggestions on the experimental design and data analysis.

Thanks to everyone in the Fisheries and Ocean Health Laboratory, especially our coordinator Megan Robillard, (you keep all this running, you know) and Judd Curtis, my fellow red snapper graduate researcher. Many thanks to lab members Alison, Becca, Jason, Jen, Laura, Matt K., Matt A., Mauricio, Peter, Phil, Ruben, Todd and Will.

Thanks to my awesome volunteers Alin, Braden, Danielle, Julianne, Kim, Nick and Stephanie.

Thanks to all my grad student friends- our cook-outs, parties and beach time have kept me sane the last two years. Briana, thanks for editing for me and always being there. I have loved my time with all the grad students here at TAMUCC, but a special thanks for your friendship to Brandon, Emily, Frank, Josh, Judd, Kate, Krista, Luke, Lindsey, Matt M., Mellissa, Paige, Paniz, Rachel F., Rachel W., Ryan, Scott, Sharon, and Travis.

Thanks to my family for all your love, always believing in me, and instilling in me the importance of education.

Thanks to my dogs Sagan and Laika for keeping me company and for your unconditional love. Lastly, as special thanks to my husband, Mark. I couldn't have done it without you. This has been an incredible journey together, and I am so excited for our future.

## INTRODUCTION

The United States began implementing fisheries rebuilding plans in the 1980's in response to assessments showing overfishing and serious declines in the health of many commercial and recreational fish stocks (Milazzo 2012). A variety of management practices were put into effect in an attempt to control overfishing and restore populations, such as size limits, bag limits, and closed seasons (Diamond and Campbell 2009). These management strategies resulted in increased catch-and-release fishing activity; implementing regulations requiring anglers to discard fish that were too small, over the bag limit, or captured out of season (Rummer 2007). Fish released because they do not meet management guidelines are known as 'regulatory discards.' More recently catch-and-release has become widespread and is developing into a cornerstone of U.S. fisheries management. However, it is only an effective strategy if most regulatory discards survive (Campbell et al. 2010a; Diamond and Campbell 2009).

Mortality of released fish has been a primary concern for fisheries managers for several decades and is especially significant if a large percentage of the catch is composed of regulatory discards (Davis and Ottmar 2006; Harrington et al. 2005; Hochhalter and Reed 2011). There are a variety of reasons that fish may not survive being captured and returned (Burns et al. 2004). Stressors include hooking, exhaustion, air exposure, vision damage from sunlight, rapid thermal change (experienced at the thermocline), and handling injuries (Brill et al. 2008; Campbell et al. 2010b; Davis and Olla 2001; Rummer and Bennett 2005). The scale and severity of discarding has prompted fisheries scientists to improve methods to quantify and predict mortality, but



there is still a paucity of data regarding mortality rates in many fisheries (Davis and Ottmar 2006; Hochhalter and Reed 2011; Pollock and Pine 2007)

Several commercially and recreationally targeted physoclistous species live deep within the water column and can suffer an additional type of stress from pressure-related injuries, collectively known as barotrauma, when they are captured and brought to the surface (Brown et al. 2009; DeMartini et al. 1996; Dowling et al. 2010; Gravel and Cooke 2008; Hannah et al. 2008; Nguyen et al. 2009; Nichol and Chilton 2006; Parker et al. 2006). Swim bladders of physoclistous fish are closed organs, and unlike physostomes such as salmonids, their swim bladder is not connected to the esophagus (Pribyl et al. 2009; Schmidt-Nielson 1997; Wilde 2009). Barotrauma, also known as catastrophic decompression, is a condition that results from swim bladder gas expanding during a forced ascent (Rummer and Bennett 2005). This occurs according to Boyle's law that states that as pressure decreases, gas expands exponentially (Pribyl et al. 2009). Forced decompression (i.e., capture from depth by hook-and-line) can cause gasses in the swim bladder to expand, displacing and damaging other organs, and may result in rupture of swim bladder tissue walls. Fish suffering from barotrauma usually exhibit additional symptoms including a distended abdomen, stomach eversion from the buccal cavity, intestinal protrusion from the anus, and eyes bulging from the head known as exophthalmia (Burns et al. 2004; Campbell et al. 2010b; Rummer and Bennett 2005). These visible signs constitute part of an extensive suite of internal and external injuries that can be caused by barotrauma (Rummer and Bennett 2005).

In addition to mortality estimates and outward signs of pressure-related injuries, barotrauma is also studied by measuring sublethal effects that can alter normal behavior

and increase vulnerability to predation (Campbell et al. 2010a; Campbell et al. 2010b). Sublethal effects include injuries (like stomach eversion and exophthalmia), impairment to reflexes, and impairment of behavioral responses (Campbell et al. 2010a; Davis and Ottmar 2006). Examples of reflex responses include the erection of the dorsal spines when a threat is perceived or an active attempt to ventilate the gills (Campbell et al. 2010a). Normal behavior includes swimming in an upright orientation and an evasion response when a predator approaches. Impairment in these categories may prevent fish from resuming necessary activities like foraging and avoiding predators (Burns et al. 2004). Once released, fish with expanded swim bladders are positively buoyant and may have difficulty orienting, submerging, and avoiding a predatory attack (Brown et al. 2010). Compounding the problem, tertiary predators like dolphins have been observed following fishing vessels and appear to have associated boats with easy prey (Burns et al. 2004). Consequently, a fish that may survive capture and release may be unable to avoid predation from a variety of aggressive predators.

Several barotrauma relief techniques have been proposed to improve survival and recovery in fisheries afflicted with barotrauma (Hochhalter and Reed 2011). One way of achieving these goals is to restore the swim bladder to a normal volume. The two primary methods used to accomplish this are swim bladder deflation with a venting tool and rapid recompression (Wilde 2009). A venting tool is a hollow needle that is used to puncture the fish's abdomen and swim bladder wall to release excess gasses (Render and Wilson 1994). In the Gulf of Mexico, it is required that anglers possess a venting device on board their vessel to be used on fish that are experiencing barotrauma. Although anglers must possess a venting tool, when it should be used it is left up to their personal discretion.

Many small fish or those captured at shallower depths may not need to be vented and needle insertion may cause additional stress without benefit. Ideally, when the swim bladder is vented it should contract to near normal size and displaced organs should return to their prior alignment. With the excess gasses removed, the fish is more likely to return to depth when released (Render and Wilson 1996). Studies on the efficacy of venting have found differing results, and proper venting technique is likely a major factor in successfully employing this relief method (Wilde 2009). Thus, it is clear that the benefits of venting may differ among species and with environmental conditions (see review by Wilde 2009) and further study is warranted.

A more recently developed method for relieving barotrauma is rapid recompression of the swim bladder gasses (Jarvis and Lowe 2008). This process aims to reverse some effects of barotrauma by returning the fish to depth and forcing the gasses in the swim bladder to recompress to their original volume (Brown et al. 2010). This method may be less invasive than venting, but it does require additional time and effort. Several devices are used to release fish at depth, such as cages and barbless hooks attached to heavy weights (descender hooks) (Brown et al. 2010; Hochhalter and Reed 2011). Most recently specialized release hooks and even devices that release fish at specified depths (Seaqualizer™) have been developed. Several studies in rockfish species have determined that discard mortality can be substantially decreased through the use of rapid recompression (Hochhalter and Reed 2011; Jarvis and Lowe 2008).

The Gulf of Mexico red snapper (*Lutjanus campechanus*) is a key example of a fishery that critically needs survival estimates of discards and evaluation of barotrauma relief methods. This species is the most economically important reef fish in the Gulf of

Mexico (SEDAR 2005), and has major commercial and recreational fisheries. Red snapper management is the most controversial of any Gulf fishery, and much of the debate revolves around regulatory discards (Cowan et al. 2011). Red snapper are a large, spiny-rayed finfish that opportunistically prey upon a variety of benthic crustaceans, worms, cephalopods and fishes (Wells et al. 2008). This species has a key ecological role as a higher trophic level predator at the natural and artificial reef sites they inhabit (Wells et al. 2008). At approximately age two they enter the fishery and are heavily exploited by fisherman for the remainder of their lives (Gallaway et al. 2009). Red snapper are routinely caught between 30 and 60 meter (m) depths and can live as deep as 110 m (Manooch et al. 1998; Rummer and Bennett 2005). Being captured from these depths routinely results in barotrauma (Rummer and Bennett 2005).

Red snapper have been overfished since at least the mid 1980's and are currently overfished relative to a risk-averse biomass benchmark, prompting intensive management for recovery (Cowan 2011; Diamond and Campbell 2009). Recently the fishery has seen some improvement and is no longer undergoing overfishing (NMFS 2012). The first stock assessment took place in 1988 and the population was found to be so overfished that a 60-70% reduction in fishing mortality was deemed necessary for the recovery of the stock (SEDAR 2005). Estimated spawning stock biomass has decreased greatly since the 1950's and continues to be far below target levels (GMFMC 2009). Stringent regulations, including size limits, bag limits, a set total allowable catch, and season closures have increased the proportion of fish that are caught and released in the recreational fishery to over 50%, ten times higher than in the 1980's (Rummer 2007).

Given the importance of this fishery, it is one of the most assessed stocks in the Gulf of Mexico, and is currently undergoing a benchmark stock assessment (GMFMC).

There have been several federal assessments and scientific studies completed to attempt to quantify the immediate and delayed mortality of discarded red snapper (Burns 2002; Diamond and Campbell 2009; Gitschlag and Renaud 1994; SEDAR 2005). While catch-and-release mortality in shallow water game fish is often low (James et al. 2007; Pope and Wilde 2004), deeper water species like red snapper have much higher mortality due to barotrauma injuries (Gitschlag and Renaud 1994). The 2005 stock assessment estimated discard mortality in the red snapper recreational fisheries at 40% for the Western Gulf and 15% for the Eastern Gulf (SEDAR 2005). Scientific studies where fish were kept in cages upon release to observe deaths found a rate of 36%-65% for fish captured below 30 m (Burns 2002; Diamond and Campbell 2009; Gitschlag and Renaud 1994). Gitschlag and Renaud (1994) found a 44% mortality rate of red snapper captured at 37-40 m and then released at the surface. However, all fish observed actively swimming down were counted as survivors, and the fish's fate once they submerged was not known. This study also contained a caged component where fish captured at 50 m were descended in cages back down to 35 m, and observed by scuba divers for 10-15 d. Descended fish had a mortality rate of 36%. In a similar study, Diamond and Campbell (2009) found a mortality rate of 64% within the first 24 hrs and an immediate mortality of 17% of fish caught between 30-50 m using caged fish. The wide variability of mortality estimates from different types of studies clearly indicates there is a need for greater research in assessing this issue and evaluating methods to increase survival of discards in the red snapper fishery.

Mark-and-recapture studies of red snapper have also been used to derive mortality estimates (Burns et al. 2004; Burns 2002; Patterson et al. 2002; Patterson et al. 2001), and these studies have found that there is the potential for individual red snapper to be caught multiple times (Burns et al. 2004; Patterson et al. 2002) and thus suffer repetitive decompression cycles. Return rates of this species have ranged from approximately 6-19% (Burns et al. 2004; Burns 2002; Patterson et al. 2002; Patterson et al. 2001). Patterson et al. (2002) determined that release condition significantly correlated with probability of recapture. In the study 19% of fish were recaptured, and 87% of them had been released with an excellent condition score and presumably experienced little barotrauma, suggesting that release condition may be a predictor of survival. This study also had 42 of 2,232 fish caught three times, and one fish was even caught a fourth time, illustrating that multiple captures can occur in this fishery. Red snapper have high potential for multiple capture events due to their site fidelity to artificial reefs like oil rigs (Schroepfer & Szedlmayer 2006) where they can experience heavy fishing pressure. If a fish is recaptured multiple times this increases the chance of several decompression events, possibly magnifying the extent of the injury. There is little data on the effect of multiple barotrauma events and it is important to estimate if multiple decompressions can cause have a negative effect on fish health or fisheries populations.

Mortality estimates conducted in the field have inherent drawbacks. The principal obstacle is the inability to document the fate of the fish after release. Thus, conducting laboratory experiments using hyperbaric chambers provides a highly controlled setting to evaluate mortality, barotrauma effects, and relief procedures while controlling for confounding events. A hyperbaric chamber is a device that can be used to simulate the

pressures fish experience at selected depths (Rummer and Bennett 2005). Previous studies using red snapper and hyperbaric chambers have evaluated physiological damage caused by barotrauma (Rummer and Bennett 2005), determined mortality rates from specific depths (Burns et al. 2004), and observed sublethal effects using a condition index (Campbell et al. 2010a). Hyperbaric studies conducted in a laboratory are also ideal for observing immediate and delayed mortality from different depths. Burns (2002) found mortality for red snapper to be 40% for fish captured from 42.7 m and 45% for fish from 61 m using hyperbaric chambers. Data on the effectiveness of barotrauma relief methods within a controlled environment and the effect of multiple barotrauma events is critically needed. Additionally, data on ability to evade a predator after release (that can be simulated in a laboratory) is necessary to fully evaluate mortality risk. No studies evaluating release methods to improve survival (i.e., venting or rapid recompression) have been performed using these chambers.

Additional data is definitely needed to quantify mortality of regulatory discards and assess tools and techniques that will increase the populations of deep dwelling fisheries that are undergoing stock rebuilding plans. Additional evaluations of the efficacy of venting or rapid recompression will aid fisheries managers in developing effective strategies to promote survival and recovery. Thus, the objectives of this study were to: 1) quantify the sublethal effects of barotrauma on red snapper; 2) estimate survival rates of red snapper that have experienced single and multiple decompression events and; 3) evaluate the effectiveness of venting and rapid recompression as techniques to increase survival and improve recovery after release. The results of this

study will be valuable in improving red snapper management strategies and advancing the population recovery of this economically and ecologically important fishery.



## METHODS

### *Fish collection and maintenance*

Red snapper were collected by hook-and line at depths of 20-40 m from reef sites south-east of Port Aransas, Texas, USA. Average fish length  $\pm$  SE was  $356 \pm 5$  mm. Fish below 405 mm in length were specifically targeted for this study to control for size-related barotrauma and because regulations in the recreational fishery require that fish below this length must be released. Upon retrieval, all fish were vented with a Team Marine<sup>®</sup> PV 2 Angler Series Pre-Vent tool and placed in the vessel's flow through live-well system for transport to the laboratory.

Experiments took place at the Texas AgriLife Research Mariculture Laboratory in Port Aransas (AgriLife) where fish were kept in indoor aerated water tanks (5600 L; 3.7 m in diameter). Water temperature was maintained at  $25 \text{ }^{\circ}\text{C} \pm 2 \text{ }^{\circ}\text{C}$ , and photoperiod was kept on a 12:12 h light-dark cycle. Water quality parameters including nitrates, nitrites, pH, and ammonia levels were monitored regularly. Fish were treated prophylactically on arrival with a 60 s freshwater dip and holding tanks were treated with 0.25 mg/L copper sulfate every other day for eight d to remove any ectoparasites or gill trematodes (Burns et al. 2004; Rummer and Bennett 2005). Initially, fish were fed a natural diet of squid, shrimp, and sardines, and they rapidly began to feed and exhibit normal behavior. To facilitate the long-term holding of fish for these experiments, all fish were converted from a natural diet to a pelleted diet (Rangen<sup>®</sup> brood trout diet, 41% protein, 14 % lipid, 6.4 mm size) and were fed to satiation three times per week (R. Phelps, Auburn University, recommended this pellet type). Fish were allowed to acclimate and recover for a minimum of 14 d prior to experiments (Campbell et al. 2010a). In the rare event a fish

was not feeding or appeared unhealthy (i.e. difficulty swimming, had white lesions etc.), it was excluded from study experimental trials.

### *Hyperbaric chambers*

Hyperbaric chambers were used to simulate pressures that a fish would experience at 30 and 60 m of depth (Figure 1). Chambers were cylindrical in shape and constructed of high-pressure tolerant, schedule 80 PVC with circular acrylic end plates. Each had a volume of 83 L, 98.5 cm length, 38 cm diameter, and a front opening 15 cm in diameter. Utilitech 1/2-HP 8-GPM 3-Wire 230-Volt submersible well pumps were used to pressurize the chamber. By slowly closing the exit flow valve and releasing less water through the return line than was coming in, pressure slowly built up inside the chamber in a controlled manner (Figure 2). Chambers were calibrated by placing a dive watch that measured depth inside and then pressurizing the system to ensure target pressures accurately corresponded to depth and that these levels were precisely and consistently maintained. Visual observations of fish were made through the clear acrylic end plates.

### *General Experimental design*

To study the effects of barotrauma on red snapper, fish were decompressed using hyperbaric chambers from three depth levels (0, 30 or 60 m), vented or non-vented, and released at surface pressure or rapidly recompressed to same pressure level they were just brought up from. Pressure changes associated with capture events were simulated by first acclimating fish inside hyperbaric chambers to pressures corresponding to 0, 30 or 60 m depths (see *Acclimation to pressure and decompression* section for details). Once fully

acclimated fish were decompressed at a rate of  $1 \text{ m/s}^{-1}$  (Table 1). Depth levels were reflective of the range of common capture depths in this fishery in the Gulf of Mexico (Campbell et al. 2010a; Rummer and Bennett 2005) and  $1 \text{ m/s}^{-1}$  is similar to the rate of ascension red snapper routinely experience when caught by hook and line (Campbell et al. 2010a). Control fish (0 m) were not subject to any pressure changes while in the chambers but were otherwise treated in an identical manner. To examine the sublethal effects of the decompression, fish were removed from the chambers and injuries and reflex responses were recorded (See *Assessment of barotrauma injuries and reflex responses (BtR)* section for details). Effectiveness of venting and rapid recompression as barotrauma relief methods were tested. Fish were either vented or not vented and then released into an open tank at ambient pressure (surface release) or returned to the chamber and rapidly recompressed to the original pressure level (See *Barotrauma relief procedures and behavior tests* section for details). Fish were monitored for immediate and delayed mortality. To evaluate the influence of venting on post-release behavior, fish released at surface pressure were tested for the ability to evade a simulated predator (a dip net) and swimming orientation was observed. Injuries, reflex responses, and post-release behaviors were all recorded on a presence-absence basis and all indices were combined into numerical barotrauma reflex (BtR) score that measured sublethal impairment. If a fish in the surface release treatment survived, the entire experiment was repeated, up to three times, to simulate the effects of multiple captures.

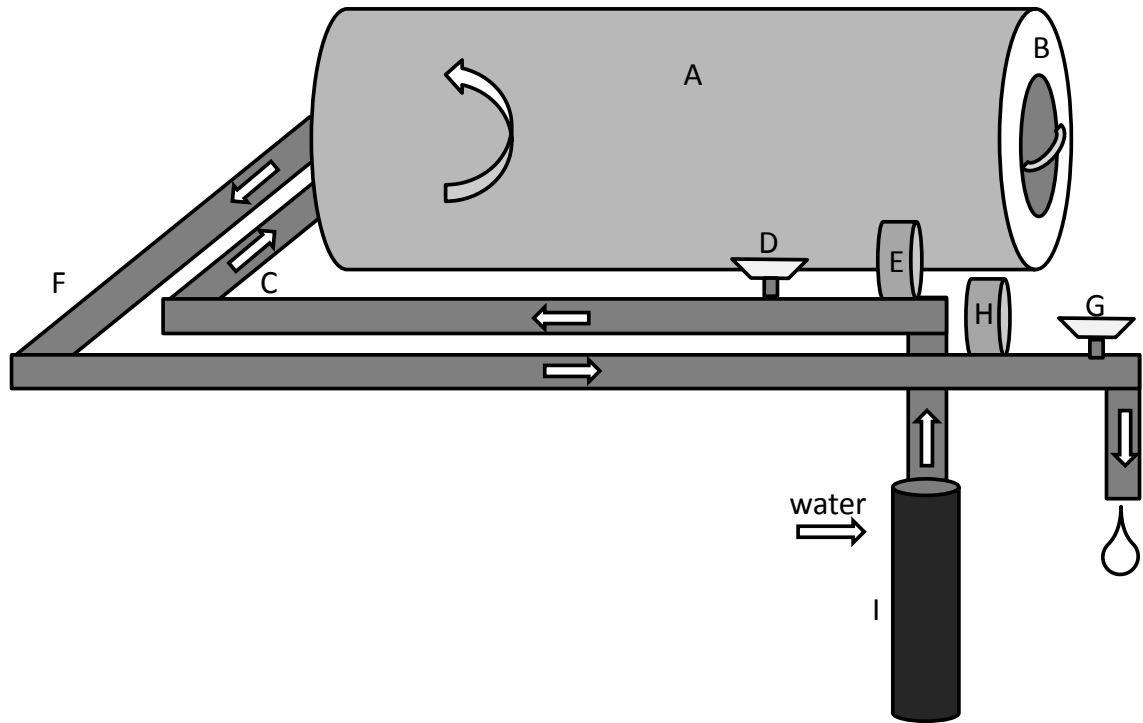

FIGURE 1. Schematic drawing of the flow-through hyperbaric chamber used to simulate the pressure changes experienced by red snapper during capture events from 30 and 60 m depths. The fish enters the pressure chamber (A) through the door opening in the acrylic endplate (B). The chamber is equipped with an inflow pipe (C), regulating valve (D) and pressure gauge (E), and an outflow pipe (F), regulating valve (G), and pressure gauge (H). A Utilitech 1/2-HP well pump (I) was used to fill and pressurize the chamber with water.

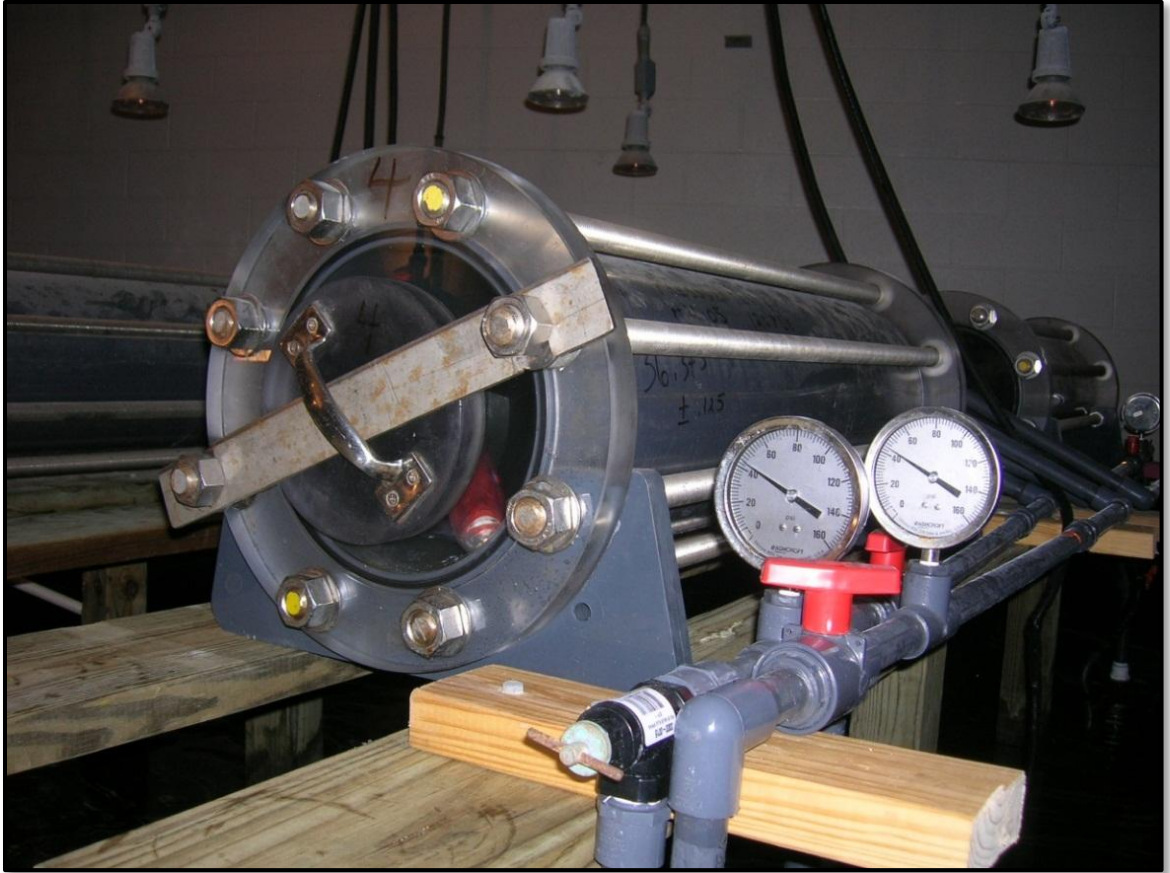

FIGURE 2. Photograph of a hyperbaric chamber used to simulate the pressure changes experienced by red snapper during hook-and-line capture events.

TABLE 1. The experimental design for conducting barotrauma studies on red snapper. There were three depth treatments: 0 m (control depth where ambient pressure was maintained), 30 m, and 60 m. Two release types were tested: 1) surface pressure, where a fish was released into an open air holding tank and 2) rapid recompression, where a fish was returned to a hyperbaric chamber and rapidly recompressed to the same pressure they were previously decompressed from. Half of all fish in each release type were vented, and the other half were not (non-vent). The sample size in each group is given by  $n$ .

<b>Depth</b>	0 m (control)				30 m				60 m			
<b>Release Type</b>	Surface Pressure		Rapid Recompression		Surface Pressure		Rapid Recompression		Surface Pressure		Rapid Recompression	
<b>Venting</b>	Vent	Non-vent	Vent	Non-vent	Vent	Non-vent	Vent	Non-vent	Vent	Non-vent	Vent	Non-vent
<b><math>n</math></b>	5	4	5	5	6	6	6	6	6	6	6	6

#### *Acclimation to pressure and decompression*

Individual red snapper were randomly assigned to pressure level treatments that corresponded to depths of 0, 30, and 60 m and after acclimation to depth fish were quickly decompressed. Control fish were held prior to experiments in an identical manner to pressurized treatments; however inside the chambers pressure was maintained at 1 ATM. Four chambers were used to provide replicate testing, and treatments were randomly assigned for each chamber. After fish were transferred to the chambers pressure was not adjusted for at least one hour to allow the fish time to acclimate to its surroundings. Over a period of 13-15 h pressure was gradually increased at intervals of approximately 3.5 PSI/h for 30 m (43.8 PSI) depth treatments and 6 PSI/h for 60 m (87.6 PSI) depth treatments. These rates were slow enough to minimize stress indicators such as hard gilling and constant fin movement to retain upright orientation. Once at the desired depth fish were kept at that pressure for at least 16 h. Total time fish were kept inside chambers for “descents” was between 29 and 32 h. After 16 h acclimation was determined to be complete when the fish maintained neutral buoyancy and minimal fin

movement (Rummer and Bennett 2005; Wilson and Smith 1985). Once a fish was fully acclimated to depth a fishing event was simulated by releasing the pressure at a rate of approximately  $1 \text{ m/s}^{-1}$ .

*Assessment of barotrauma injuries and reflex responses*

After decompression red snapper were removed from chambers and examined for sublethal effects using a modified version of the condition index described in Campbell et al. (2010a). The condition index used was the barotrauma reflex (BtR) score, and all injuries and reflex responses recorded were binary in nature (1= unimpaired state, 0 = impaired state). To calculate the BtR score, the sum of the total number of unimpaired indices was divided by the maximum score of seventeen, and subtracted from one using the following equation (Campbell et al. 2010a).

$$\text{BtR} = 1 - [(\Sigma \text{ individual responses}) / \text{total responses possible}]$$

A score close to 1 indicated high levels of impairment, while a score close to zero indicated a less impaired fish. The fish was evaluated for a set of barotrauma-related injuries, including an enlarged abdomen that was hard to the touch (tightened swim bladder), intestinal protrusion from the anus, stomach eversion into the buccal cavity, subcutaneous hemorrhaging, exophthalmia (eyes bulging out from the head) and inactivity. Reflex responses included gag, opercular, dorsal spine, hypaxial-muscle flex, and vestibular-ocular (VO). The gag response was measured by inserting a probe into the fish's esophagus and an unimpaired response (score of one) was recorded if the fish contracted its jaw or tried to expel the probe. An unimpaired opercular response was noted if the fish was actively moving its gill flaps. The dorsal spines were pushed down with a probe and considered uninhibited if they re-extended into the erect defense

position. A response of “one” was recorded for hypaxial response if the subject demonstrated hypaxial-muscle contraction (tail flapping). Lastly, vestibular-ocular response was tested by moving the fish’s cranium along its lateral axis and was unimpaired if the eyes rotated to refocus on the human observer. After all BtR indices were evaluated, total length was recorded and the fish was tagged with an external T-bar Floy™ tag printed with a unique ID number. The entire process took between one and three min and handling time was recorded for each subject.

#### *Barotrauma relief procedures and behavior tests*

To evaluate the effectiveness of two barotrauma relief procedures, there were four treatments and controls. Fish were either vented and released at surface (ambient) pressure, non-vented at surface pressure, vented and rapidly recompressed, or non-vented and rapidly recompressed (Table 1). The treatment of fish that were vented and rapidly recompressed received both relief methods. It is probably unnecessary to use both procedures on the same fish, but this treatment was included to ensure a fully-crossed experimental design. After evaluation of injuries and reflex responses, fish were either vented with a hollow metal venting tool or not vented (non-vent) according to treatment.

Fish in the rapid recompression group were returned to the hyperbaric chamber and rapidly recompressed to the pressure corresponding with that subject’s depth group (0, 30 or 60 m). This process took between one and two min. Rapid recompression is reflective of a fish in the field being returned to depth prior to release with a cage or descending apparatus. Fish were monitored inside the chamber over the next 1-3 hours for immediate mortality and checked again the following morning after fish were maintained at depth for approximately 16 hours. Recovery for longer-term observation



represented an additional challenge, as it was necessary to bring fish back to surface pressure while avoiding barotrauma. Thus, over the next three days pressure in the chamber was slowly and incrementally returned to zero PSI to bring the fish to surface pressure and allow for removal from the chamber. This time frame was used to mitigate additional barotrauma injuries from bringing fish to 1 ATM while minimizing stress associated with being inside the chamber (i.e., not eating). Fish were monitored for at least three weeks to evaluate any delayed mortality or long-term effects from barotrauma.

Red snapper in the surface release treatment were transferred into an open-air water tank where they underwent behavioral tests. It was not possible to subject rapidly recompressed fish to behavioral tests, as the fish were "compressed" inside the hyperbaric chamber. Release into a holding tank represents what a fish would experience when discarded overboard from a boat. Immediately after entering the water of the holding tank (time zero), and after 5 min and 15 min, the subject was examined for an upright orientation in the water, and tested for the ability to evade a simulated predator. Observation at 0, 5 and 15 min post-release allowed for investigation of time-course impairment (Campbell et al. 2010a). These scores were also binary, and an unimpaired response (score of one) was recorded if a fish was upright and swimming normally, as opposed to sideways or upside-down. At each time interval predator simulations were done by quickly thrusting a dip net towards the fish. An unimpaired response was noted if the fish was able to evade capture. Behavioral scores were included in the condition index, and these were added to the injury and reflex indices to compute a total BtR impairment score for each fish. There were 11 injury and reflex indices and 6 behavioral indices, for a

total of 17 used to calculate the BtR score. After behavioral tests fish were monitored for between one and three hours for mortality and then checked again the next morning.

To assess the effect of multiple decompression events, any fish that survived a surface release was subjected to another simulated fishing event at the same depth. Fish were considered ready for another decompression event when they resumed aggressive feeding, theoretically giving the fish the potential to be recaptured by anglers. The second decompression event typically occurred between two and three days after the first one. This process was repeated up to three times for each fish. A preliminary experiment conducted to determine how many decompression events a fish could survive indicated that when vented, fish can survive at least 5 decompression events. I chose three as the number of decompression events for surface release treatments because mark and recapture experiments have rarely seen fish caught more than three times (Burns 2002; Patterson et al. 2002). To represent the fishery as it exists today, red snapper in rapid recompression treatments underwent only one barotrauma event, as currently decompression tools are gaining some popularity but are rarely used by the angling public. In addition, the amount of time to complete a recompression experimental trial was five days. This would have resulted in the fish remaining in the chamber for an extraordinary amount of time, and this could have confounded the study. To evaluate any delayed mortality or long-term sublethal barotrauma effects, all fish that survived three surface pressure release events or one rapid recompression event were monitored in holding tanks for at least three weeks.

### *Data analysis*

The response variable for barotrauma sublethal effects was the BtR score; a number between zero and one. If a fish did not survive a decompression event, it was given a BtR score of one for subsequent events, indicating total impairment. A linear regression was used to test for the effects of fish length on BtR score. A Student's *t*-test ( $\alpha = 0.05$ ) was used to assess differences in fish BtR scores between venting treatments for each decompression event. I tested for differences in BtR score among all treatments using a two-way analysis of variance (ANOVA) with depth (0, 30 and 60 m) and venting (vent and non-vent) as main effects ( $\alpha = 0.05$ ). The same fish underwent multiple decompression events, so a two-way repeated-measures ANOVA was also performed with event number (1, 2 or 3), depth and venting as main effects. Significant main effects were further examined using Tukey's honestly significant difference (HSD) *post-hoc* tests. The effects of depth were determined by calculating a depth-BtR score that included the 11 indices recorded before the fish was vented (behavior indices were not included). The regular BtR score is calculated using all 17 indices. A one-way ANOVA was used to assess the differences among depths on depth-BtR score. A binary exact logistic regression was used to determine differences in treatment in predicting survival (Derr 2000). This technique is more robust for small sample sizes than a regular logistic regression model (Hirji et al. 1987). All statistical analyses were conducted using SAS 9.2 software.

## RESULTS

Overall, depth of capture resulted in higher BtR scores (more impairment). Non-vented fish had higher BtR scores than vented fish after both single and multiple decompression events. Behaviorally, non-vented fish showed greater difficulty achieving an upright orientation and less ability to evade a simulated predator than vented fish. All fish in vented treatments had 100% survival after a single capture event. Non-vented fish had lower survival compared with vented fish and survival decreased at greater depth treatments. Rapid recompression improved survival compared to fish released at surface pressure and 96% of all rapidly recompressed fish survived. Multiple decompressions also resulted in higher BtR scores and lower survival in all treatments.

A total of 67 fish were used in these experiments, with 33 in surface release treatments and 34 in rapid recompression treatments. Fish in all treatments were similar in size and a linear regression showed no relationship between fish length and BtR score ( $t = 42.92$ ,  $df = 15$ ,  $r^2 = 0.002$ ,  $P = 0.9234$ ). Water quality parameters did not vary from recommended ranges during the course of the experiment.

### **Sublethal effects of barotrauma/ BtR scores**

#### *Percent occurrence of sublethal indices*

The percent occurrence of specific barotrauma symptoms and reflex responses varied by individual but generally showed a negative relationship with depth (Table 2). A tightened swim bladder (enlarged abdomen) and stomach eversion were the most frequently seen barotrauma symptoms. Fish in rapid recompression treatments had tightened bladders 100% of the time in all non-control treatments (Table 2).

Exophthalmia was only observed in 60 m depth treatments. Fish frequently failed the

gag, opercular (gilling) and dorsal spine reflexes while there was only one fish that did not display the vestibular-ocular response. The hypaxial-muscle flex, or tail flapping, was usually observed, showing 17% or less impairment per treatment group. Control fish (0 m) rarely showed impairment, though lack of gag reflex and opercular response was observed in a small percentage of surface-release controls (Table 2).

TABLE 2. Percent occurrence of red snapper exhibiting barotrauma symptoms and impaired reflex responses after decompression from depths of 0, 30 or 60m. After decompression fish were released at surface (ambient) pressure into an open holding tank or rapidly recompressed. Includes scores from three decompression events. Venting treatments within each depth group are not shown separately because symptoms and reflex responses are recorded before a fish is vented.

	Depth <i>n</i>	Surface Pressure			Rapid Recompression		
		0 m 9	30 m 12	60 m 12	0 m 10	30 m 12	60 m 12
<b>Symptoms and Responses</b>							
<i>Barotrauma symptoms (%)</i>							
Tightened bladder		0	97	84	0	100	100
Stomach Eversion		0	55	56	0	33	58
Intestinal Protrusion		0	0	16	0	17	17
Exophthalmia		0	0	28	0	0	0
Subcutaneous Hemorrhage		0	14	36	0	0	0
Inactivity		0	14	8	0	8	17
<i>Impaired Reflex Responses (%)</i>							
Gag		15	52	52	0	33	33
Opercular		4	14	32	0	17	25
Dorsal Spine		0	34	28	0	25	25
Vestibular-Ocular		0	0	4	0	0	0
Hypaxial-muscle flex		0	17	8	0	8	17

*Effects of venting at surface pressure*

The BtR index showed that non-vented red snapper had greater sublethal effects from barotrauma than vented red snapper when released at surface pressure. After one decompression event non-vented fish in surface release treatments had significantly higher BtR scores than vented fish ( $t = 3.25$ ,  $df = 15$ ,  $P = 0.004$ ) (Figure 3). A higher score indicated greater relative impairment as measured by the BtR index. Mean BtR scores  $\pm$  standard error (SE) for non-vented fish and vented fish were  $0.36 \pm 0.06$  and  $0.14 \pm 0.03$ , respectively. Fish in non-vented treatments had higher BtR scores primarily due to failed behavioral tests. Generally, vented fish were able to swim normally and avoid the dip nets at all three time intervals (after 0, 5, and 15 min) (Table 3). In contrast, non-vented fish showed difficulty achieving an upright orientation, and their increased buoyancy caused them to float upside-down in the tank (Table 3). Some fish were able to move quickly and swim away within the first 5 seconds after release resulting in a “pass” for their “0 min” response; however, by 30 seconds most non-vented subjects were floating upside-down at the surface and showed no response when a dip net was thrust towards them to simulate a predator. There was no improvement the condition of these fish within the 15 min interval, and most fish were still inverted at the surface after 60 min. Fish brought up from 30 m and vented failed to evade a predator and had an abnormal orientation only 18% of the time at 5 min post-release, and 12% of the time after 15 min (Table 3). Similarly, non-vented fish in the same depth treatment failed both behavior tests 100% of time at both 5 and 15 min (Table 3). Occasionally, control fish did not pass behavioral tests; thus there may be some handling effect on the BtR score. The scores increased from the first event to the third event and non-vented fish had

significantly more impairment than vented fish ( $t = 2.98$ ,  $df = 15$ ,  $P = 0.0056$ ) (Figure 3).

Non-vented fish had a mean BtR score ( $\pm$  SE) of  $0.67 \pm 0.1$  while vented fish averaged

$0.39 \pm 0.08$ .

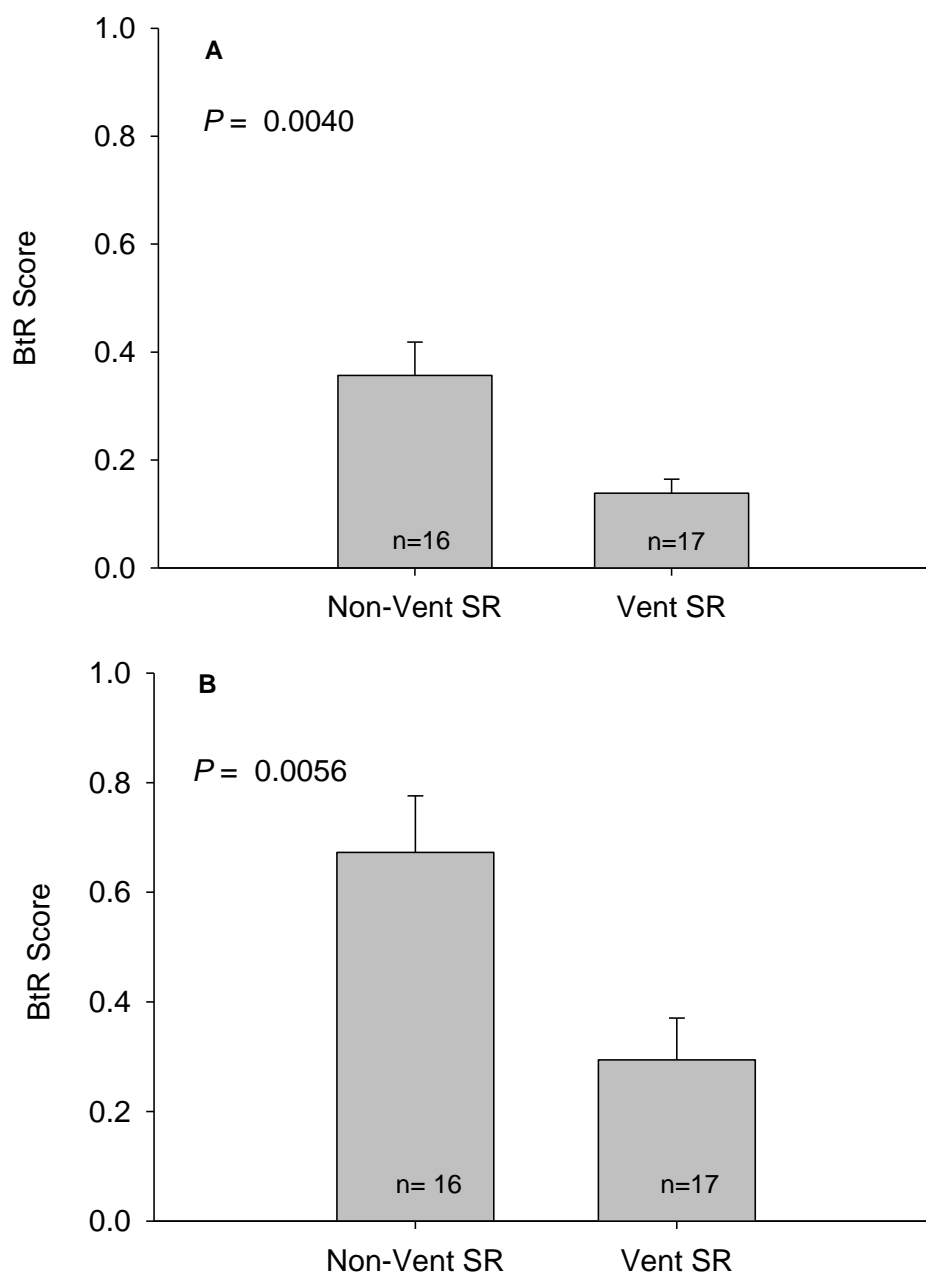

FIGURE 3. Relative impairment, as shown by mean barotrauma reflex (BtR) scores ( $\pm$  SE), of red snapper that have been decompressed from depth (A) one time or (B) three times and then vented and surface released (Vent SR) into an open holding tank or non-vented and surface released (Non-Vent SR). A higher score indicates greater impairment from barotrauma. Treatments include combined scores from 0 (controls), 30 and 60 m depth treatments. Significant results from paired Student's *t*-tests are shown with given *P*-values.



TABLE 3. Percent occurrence of red snapper exhibiting impaired behavioral responses after decompression from depth and release at surface (ambient) pressure in each venting and depth treatment combination. Behavioral responses were tested at 0, 5 and 15 min post-release. Each value represents the percent occurrence that a fish had an abnormal orientation (could not stay upright and swim normally) or could not evade a simulated predator at that time interval and treatment combination.

	Depth <i>n</i>	Vent			Non-vent		
		0 m 5	30 m 6	60 m 6	0 m 4	30 m 6	60 m 6
<i>Impaired Behavioral Responses (%)</i>							
Abnormal Orientation- 0 min		0	24	24	8	33	50
Failed to Evade Predator- 0 min		0	24	29	8	33	62.5
Abnormal Orientation- 5 min		0	18	12	15	100	87.5
Failed to Evade Predator- 5 min		0	18	12	15	100	87.5
Abnormal Orientation- 15 min		0	12	12	15	100	87.5
Failed to Evade Predator-15min		0	12	12	15	100	87.5

Red snapper impairment was also evaluated by each depth and venting treatment combination for fish released at surface pressure. There were significant differences among treatments after one decompression event (ANOVA;  $F = 28.96$ ;  $df = 5$ ;  $P < 0.0001$ ; Figure 4). The 30 and 60 m non-vented fish had significantly higher BtR scores than all other groups (Figure 4; Table 4). Venting resulted in lower BtR scores, and the 30 m vented treatment was not significantly different from the vented controls. The BtR scores after three decompression events were higher than scores from the first event in every group (Table 4), and showed significant differences among treatments (ANOVA;  $F = 14.84$ ;  $df = 5$ ;  $P < 0.001$ ; Figure 4). After three events 30 m non-vented fish no longer showed a difference from the vented treatments, the 60 m non-vent group still had significantly higher impairment than all vented fish (Figure 4).

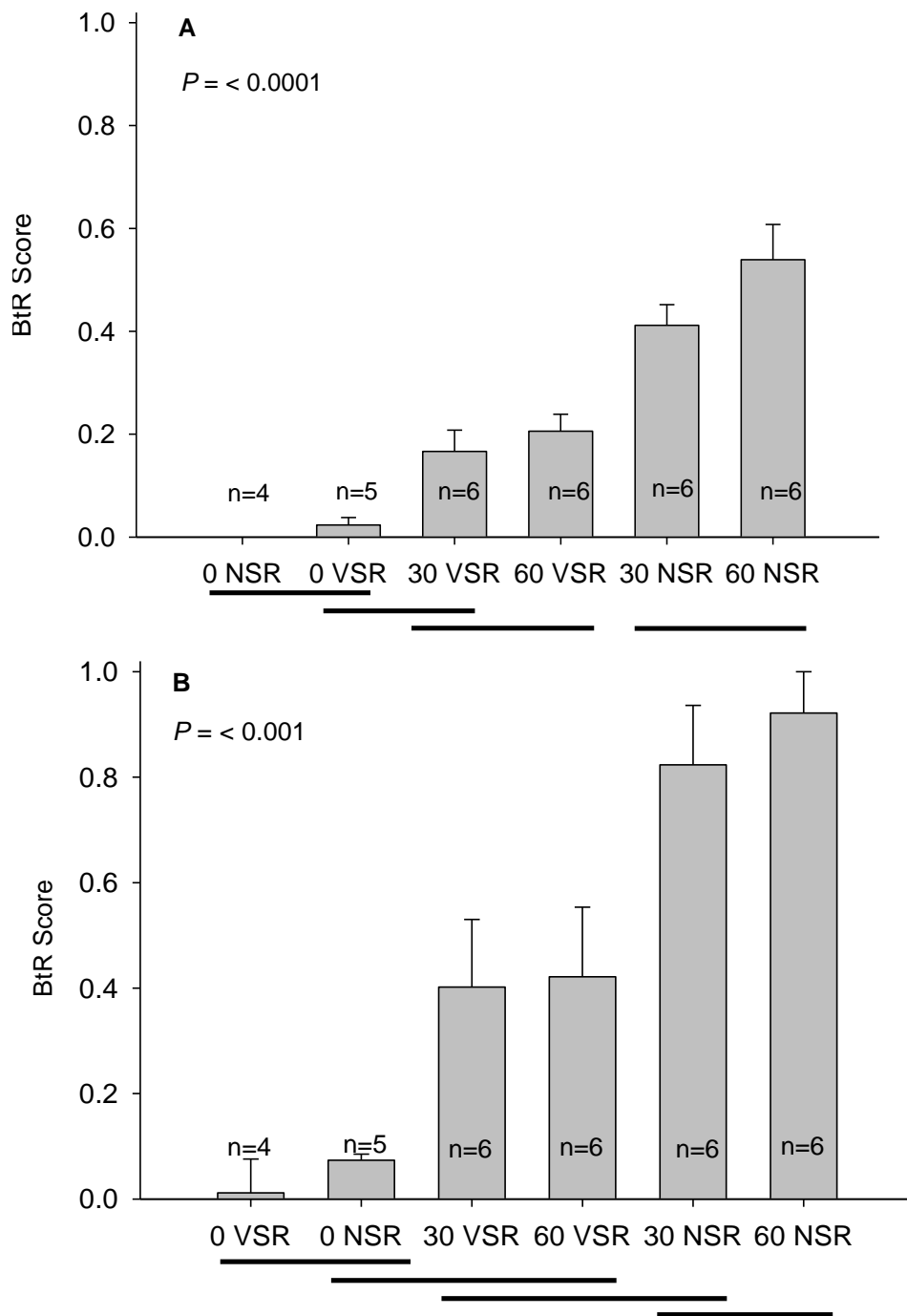

FIGURE 4. Relative impairment, as shown by mean barotrauma reflex (BtR) scores ( $\pm$  SE), among treatments of red snapper that have been decompressed from 0, 30 or 60 m depths (A) one time or (B) three times and then vented and surface released (VSR) into an open holding tank or non-vented and surface released (NSR). A higher score indicates greater impairment from barotrauma. Significant results from a two-way analysis of variance are shown with given  $P$ -values. Horizontal lines represent results from Tukey's *post-hoc* tests. Columns that do not share a horizontal line are significantly different ( $\alpha = 0.05$ ).

TABLE 4. Relative impairment, as shown by mean barotrauma reflex (BtR) scores ( $\pm$  SE), of red snapper that have been decompressed from 0, 30, or 60 m depths (A) one time or (B) three times and then vented and surface released (VSR) into an open holding tank or non-vented and surface released (NSR). A higher score indicates greater impairment. Tukey's *post-hoc* groupings for each trial are shown with the letters A-D.

<b>A. Event 1</b>			
Treatment			
Depth and Venting	Mean BtR Score	SE	Grouping
0 m NSR	0.00	0.00	A
0 m VSR	0.02	0.01	A B B
30 m VSR	0.17	0.04	C B
60 m VSR	0.21	0.03	C
30 m NSR	0.41	0.04	D
60 m NSR	0.54	0.07	D
<b>B. Event 3</b>			
Treatment			
Depth and Venting	Mean BtR Score	SE	Grouping
0 m NSR	0.01	0.06	A
0 m VSR	0.07	0.01	A B B
30 m VSR	0.40	0.13	C B C
60 m VSR	0.42	0.13	C C
30 m NSR	0.82	0.11	C D
60 m NSR	0.92	0.08	D

A two-factor repeated-measures ANOVA was used to evaluate the effects of depth and venting over three decompression events. There were significant interactions between depth and venting (ANOVA;  $F = 7.6$ ;  $df = 2$ ;  $P = 0.0024$ ) (Table 5). The test was repeated analyzing depth and venting separately. Both depth ( $P < 0.0001$ ) and venting ( $P < 0.001$ ) had a significant effect on BtR score (Table 6). In vented treatments BtR scores were not different between 30 and 60 m, driving the significant interaction (Figure 5). Results from Tukey's *post-hoc* tests showed that for all three decompression events 30 and 60 m treatments were not significantly different from one another, but they were both significantly higher than the controls, and also that non-vented fish had significantly higher scores than vented fish for all three events (Figure 5). The most impaired fish in each decompression event came from the 60 m non-vented group, followed by the 30 m non-vented (Figure 5; Table 7). Control fish showed little change in score over the three events. In all other treatments scores were positively related to their number of decompression events (Table 7). The greatest increase in mean BtR score ( $\pm$  SE) between events was from event one to event two for 60 m non-vented fish. Scores increased from  $0.539 \pm 0.069$  to  $0.902 \pm 0.098$  (Table 7). In vented treatments, BtR scores showed little variation between 30 and 60 m depths (Figure 5).

TABLE 5. Results of a two-factor repeated measures analysis of variance for the effects of depth and venting on red snapper barotrauma reflex (BtR) score over three decompression events. BtR score is an index of barotrauma impairment for red snapper that have been decompressed from depth.

SOURCE	<i>df</i>	Sum of Squares	Mean Square	<i>F</i>	<i>P</i>
<u>Between subjects</u>					
depth	2	4.50	2.25	36.0	<0.0001
venting	1	1.93	1.93	30.8	<0.0001
depth* venting	2	0.96	0.48	7.6	0.0024
Error	27	1.69	0.06		
<u>Within subjects</u>					
trial	2	0.77	0.39	17.0	<0.001
trial* depth	4	0.27	0.07	3.0	0.027
trial* venting	2	0.12	0.06	2.60	0.087
trial* depth*					
venting	4	0.09	0.02	1.0	0.415
Error (trial)	54	1.22	0.02		

TABLE 6. Results of a repeated measures analysis of variance for the effects of (A) depth and (B) venting on red snapper barotrauma reflex (BtR) score over three decompression events. BtR score is an index of barotrauma impairment for red snapper that have been decompressed from depth.

<b>A. Depth</b>					
SOURCE	<i>df</i>	Sum of Squares	Mean Square	<i>F</i>	<i>P</i>
<u>Between subjects</u>					
depth	2	4.55	2.27	13.64	<0.0001
Error	30	5.00	0.167		
<u>Within subjects</u>					
trial	2	0.763	0.381	15.8	<0.001
trial*depth	4	0.280	0.070	2.9	0.0291
Error(trial)	60	1.44	0.024		
<b>B. Venting</b>					
<u>Between subjects</u>					
venting	1	2.68	2.68	12.1	0.0015
Error	31	6.87	0.222		
<u>Within subjects</u>					
trial	2	0.926	0.463	18.2	<0.001
trial*venting	2	0.153	0.076	3	0.0569
Error(trial)	62	1.57	0.025		

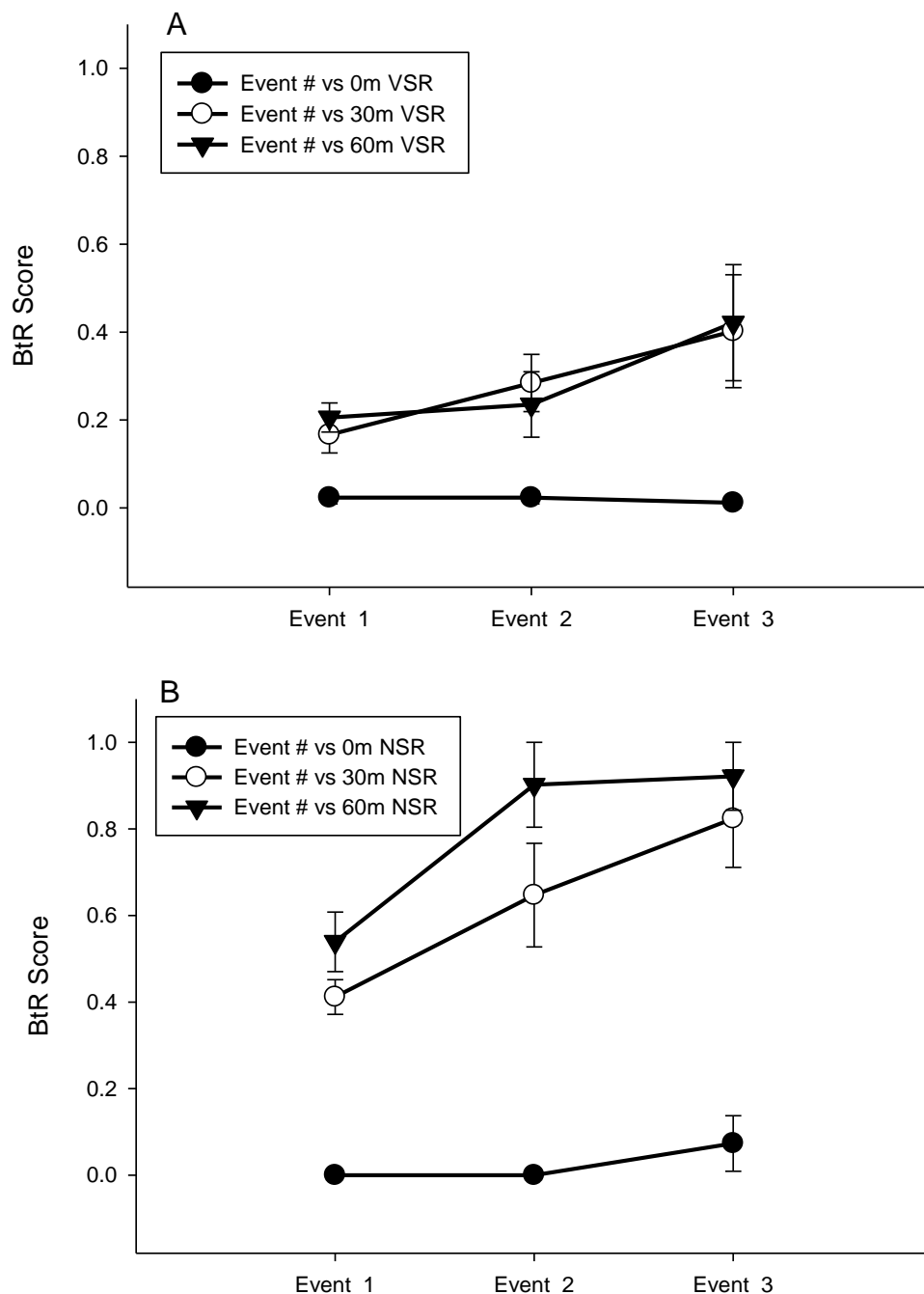

FIGURE 5. Relative impairment, as shown by mean barotrauma reflex (BtR) scores ( $\pm$  SE), of red snapper that have undergone three decompression events from 0, 30 or 60 m depths and then were (A) vented and surface released (VSR) into a holding tank or (B) non-vented and surface released (NSR). Fish was subject to the same depth and venting group for each event. A higher score indicates greater impairment from barotrauma. Tukey's *post-hoc* tests showed significant differences in non-vented and vented treatments for all decompression events, and showed that while 30 and 60 m depths were not different from each other, they were both significantly higher than controls for all events.

TABLE 7. Relative impairment, as shown by mean barotrauma reflex (BtR) scores ( $\pm$  SE), of red snapper that have been decompressed from 0, 30, or 60 m depths and then vented and surface released (VSR) into an open holding tank or non-vented and surface released (NSR). Scores are for decompression events one, two and three.

Event #	Treatment											
	0 m NRS	SE	0 m VSR	SE	30 m NSR	SE	30 m VSR	SE	60 m NSR	SE	60 m VSR	SE
1	0	0	0.024	0.014	0.412	0.040	0.167	0.041	0.539	0.069	0.206	0.033
2	0	0	0.024	0.014	0.647	0.120	0.284	0.065	0.902	0.098	0.235	0.074
3	0.074	0.064	0.012	0.012	0.824	0.113	0.402	0.128	0.922	0.079	0.422	0.132

### Depth effects on sublethal impairment

A one-way ANOVA was used to determine the effects of depth on depth-BtR score. To evaluate only the effects depth, (and to exclude the effects of venting) depth-BtR score was calculated using the 11 barotrauma symptoms and reflex tests that were recorded before the fish was vented, and did not include the six behavioral tests that took place post-venting. This analysis used the depth-BtR scores of fish in all treatments from their first decompression event. There were significant differences among depths (ANOVA;  $F = 35.52$ ;  $df = 2$ ;  $P < 0.001$ ), and Tukey's *post-hoc* tests found that 0 m, 30 m, and 60 m depths were all significantly different (Figure 6).

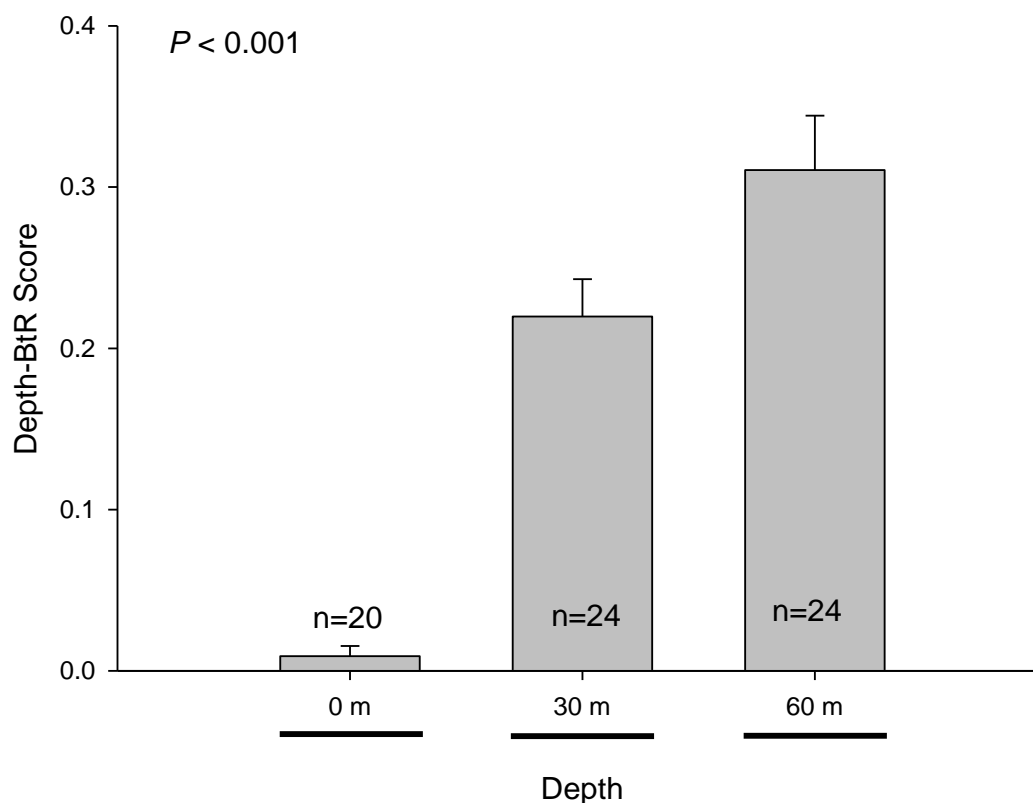

FIGURE 6. Relative impairment from decompression injuries, as shown by depth-barotrauma reflex (depth-BtR) scores ( $\pm$  SE), of red snapper that have been decompressed from 0, 30 or 60 m depths. Includes depth-BtR scores of fish from all treatments. Horizontal lines represent results from Tukey's *post-hoc* tests. Columns that do not share a horizontal line are significantly different ( $\alpha = 0.05$ ).



## Survival

### *Survival rates after one decompression event*

Red snapper in surface and rapid recompression treatments were monitored for survival after their first decompression event. There were 24 fish in vented treatments in the study and 100% survived their first trial (Figure 7). When all depths were combined within release treatment, vented rapid recompression (VRR) and vented surface release (VSR) both had 100 % survival after one simulated fishing event, while non-vented rapid recompression (NRR) had 83%, and non-vented surface release (NSR) only 42 % survival (Figure 7). All vented fish lived, so venting was not used as a variable for determining survival in the exact logistic regression. Overall, rapid recompression had a 96% survival rate. Only one death was observed in the 60 m non-vented group resulting in 83% survival in the treatment (Table 8). Rapid recompression significantly improved survival ( $P < 0.05$ ; Table 9). The odds ratio of the exact logistic regression showed a fish that was rapidly recompressed, vented or non-vented, was 9.7 times more likely to survive than one released at surface pressure. Rapidly recompressed fish showed high survival regardless of venting treatment. When surface release treatments were examined by depth, all controls and vented fish lived, while 67% of 30 m non-vented fish and only 17% of 60 m non-vented fish survived one decompression event (Table 8). There was a significant effect of depth on survival ( $P < 0.05$ ; Table 9). Fish that were decompressed from 30 m were 4.1 times more likely to live than fish captured from 60 m. During the course of the experiments all mortality occurred within 18 hours of decompression, and most died within the first hour. All fish that survived decompression were monitored for at least three weeks and no delayed mortality was observed.

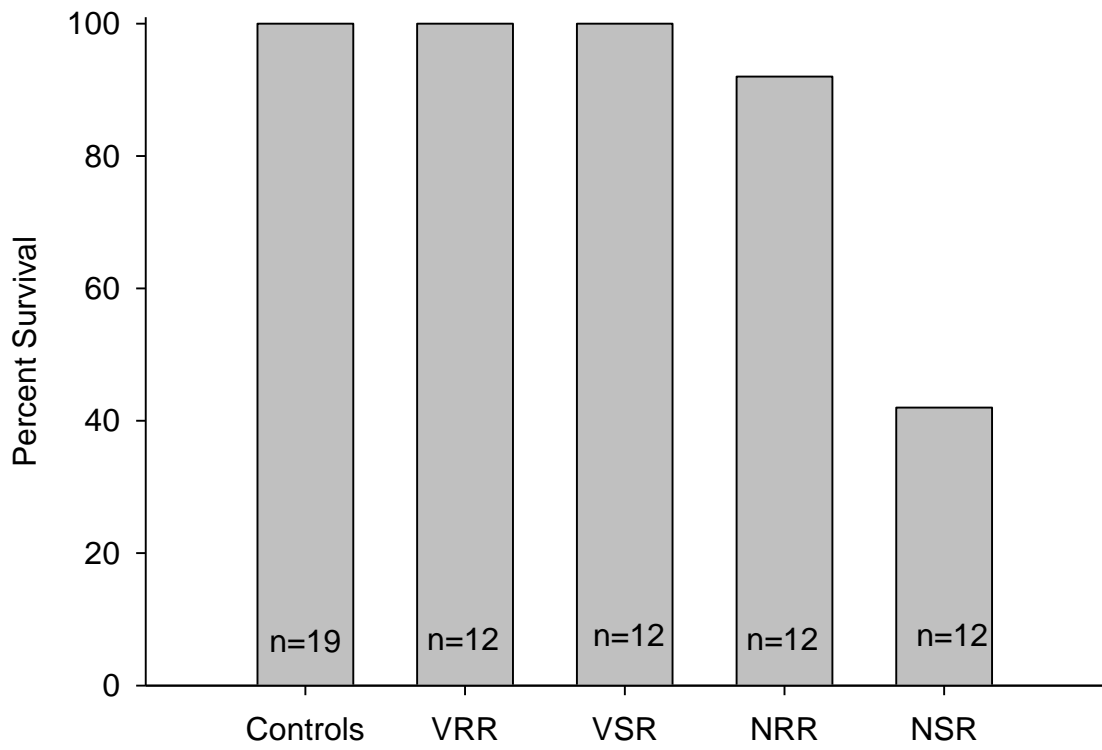

FIGURE 7. Percent survival of red snapper decompressed from depth and then vented and rapidly recompressed (VRR), vented and surface released (VSR) into an open holding tank, non-vented and rapidly recompressed (NRR) or non-vented and surface released (NSR). Control fish were not subject to pressure changes but otherwise experienced identical treatment. The other four treatments shown include combined scores from 30 and 60 m depth treatments.

TABLE 8. Effects of depth and release type on survival of red snapper subject to rapid decompression using exact logistic regression.

<u>Conditional Exact Tests</u>				
<b>Effect</b>	<b>Test</b>	<b>Statistic</b>	<b>P-value</b>	
			<b>Exact</b>	<b>mid</b>
depth	Score	6.94	0.0280	0.0254
	Probability	1.93	0.0383	0.0357
release	Score	5.45	0.0442	0.0340
	Probability	0.0205	0.0442	0.0340

<u>Exact Odds Ratios</u>				
<b>Parameter</b>	<b>Estimate</b>	<b>95% Confidence Limits</b>		<b>P-value</b>
		<b>lower</b>	<b>upper</b>	
depth 0 m	8.69	1.09	$\infty$ *	0.0407
depth 30 m	4.06	0.563	50.3 *	0.211
Release- rapid recompression	9.70	1.04	490 *	0.0442

\* Denotes a 95% confidence interval of the parameter estimate that did not include zero.

TABLE 9. Percent survival of red snapper decompressed from depth one time, released at surface (ambient) pressure or rapidly recompressed, and vented or not vented. Control fish were not subject to pressure changes but otherwise underwent identical treatment. The sample size in each group is given by *n*.

Depth	0 m (control)				30 m				60 m			
	Surface Pressure		Rapid Recompression		Surface Pressure		Rapid Recompression		Surface Pressure		Rapid Recompression	
Release Type	Vent	Non-vent	Vent	Non-vent	Vent	Non-vent	Vent	Non-vent	Vent	Non-vent	Vent	Non-vent
<i>n</i>	5	4	5	5	6	6	6	6	6	6	6	6
% Survival	100	100	100	100	100	67	100	100	100	17	100	83

### *Survival rates after multiple decompression events*

Red snapper in surface release treatments underwent barotrauma events up to three times, and survival generally decreased with multiple barotraumas in vented and non-vented groups. After three trials fish in the 30 m and 60 m vented groups had 83% and 67% remaining survival, respectively (Figure 8). The 30 m non-vented group had 33% survival and 60 m non-vented had only 17% survival (Figure 8). The greatest decline in survival for all trials was in the 60 m non-vented fish group where only 17% were alive after the first decompression (Figure 9). This was followed by 30 m non-vented fish where there was a 34% decline in survival between trial one and trial two (Figure 9). The results show greater survival of vented treatments compared to non-vented. Fish that survived multiple barotraumas were observed for three weeks and no delayed mortality occurred.

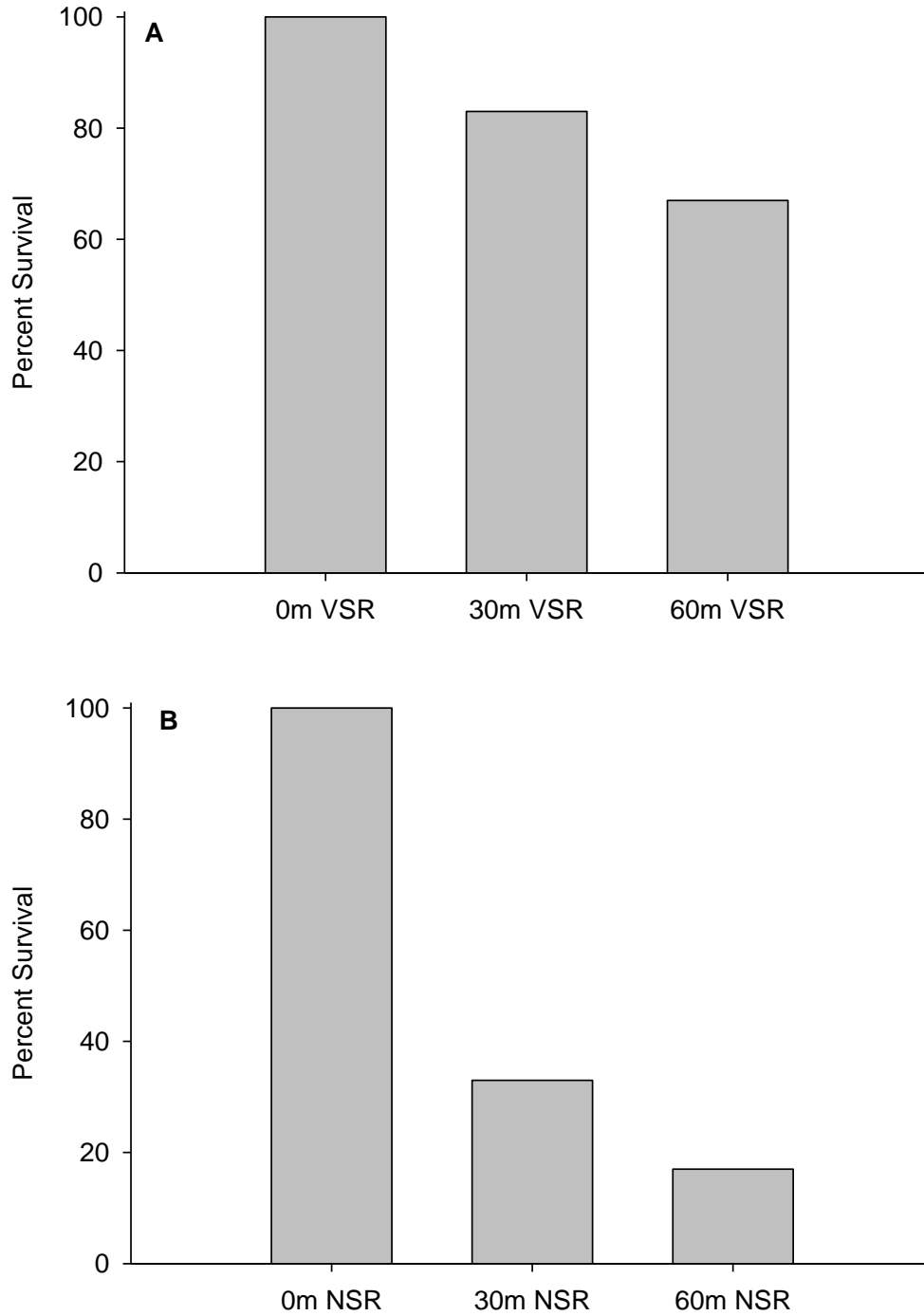

FIGURE 8. Percent survival of red snapper by treatment group after three decompression events. Fish were decompressed from depths of 0, 30 or 60 m and (A) vented and surface released (VSR) into an open holding tank or (B) non-vented and surface released (NSR).

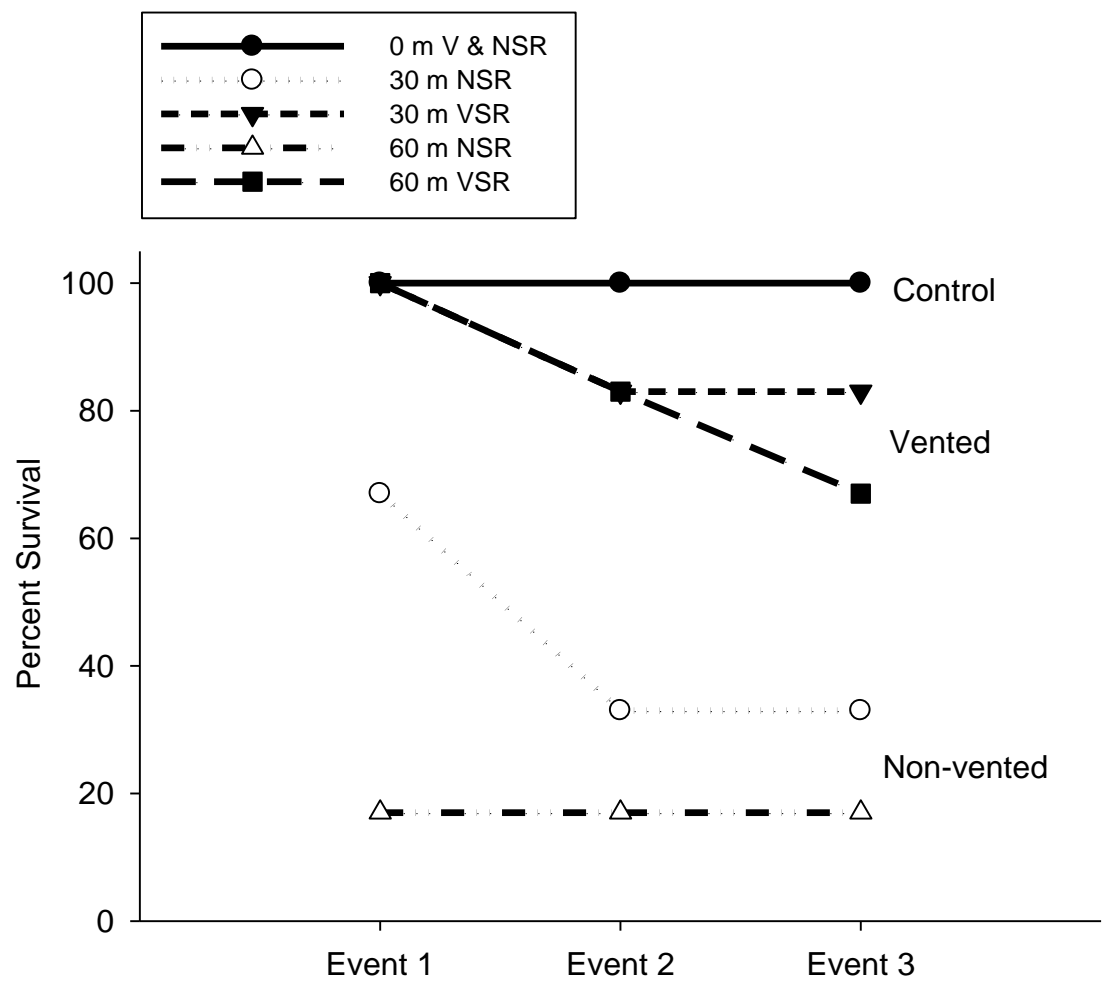

FIGURE 9. Percent survival of red snapper by treatment group after each of three decompression events. Fish were decompressed from depths of 0, 30 or 60 m and vented and surface released (VSR) into an open holding tank or non-vented and surface released (NSR).

## DISCUSSION

The findings from this study clearly show that venting or rapid recompression can improve recovery and increase survival of regulatory discards in the red snapper fishery. All vented fish, regardless of depth, survived their first decompression event; while non-vented fish had much lower survival. Vented fish showed better recovery upon release and had less difficulty orienting themselves and greater ability to evade a simulated predator. Fish that were rapidly recompressed had an overall survival rate of 96% and had a higher probability of survival than those released at the surface. There was a strong depth effect with fish captured from 60 m sustained greater injuries and had lower survival than those from 30 m. Multiple decompression events on individual fish yielded higher BtR scores and lower survival.

### **Survival rates and sublethal effects from barotrauma**

#### *Venting*

The results of this study indicate that venting improved survival compared to non-venting after single and multiple barotrauma events. Venting also improved indices of recovery, as shown by the significantly lower BtR scores in vented fish compared to non-vented fish. Specifically, vented fish were more likely to quickly gain an upright orientation and to evade a simulated predator. Red snapper in this study that were not vented (other than controls) had a difficult time staying upright and often floated upside down at the surface for prolonged durations of time before recovering, usually over an hour. Thus, my results show that venting a fish will increase its chances of surviving barotrauma injuries, and also improve its ability to avoid predation upon release.

My study improves on several of the limitations and issues seen in field studies on this same topic and illustrates that when performed correctly; venting is a beneficial practice for barotrauma relief. All fish in my study were vented initially when collected, so during experiments they actually underwent their 2<sup>nd</sup>, 3<sup>rd</sup>, and 4<sup>th</sup> venting events, further showing that this action does not have negative effects. However, the practice of venting fish has been controversial in the literature. Wilde (2009) reviewed studies on 21 species examining whether venting promotes the survival of released fish. He calculated a relative risk score for each study based on the probability of an event (survival or recapture) in a treatment group (vented fish) divided by the probability of that event in a control group (unvented fish). Overall, the review concluded that venting did not increase survival and should not be recommended. Included in this paper were four studies involving red snapper (Burns 2002; Gitschlag and Renaud 1994; Render and Wilson 1996; Render and Wilson 1994). While gas bladder deflation was a component of all these studies, their focus was generally on factors such as release type, fish length, hook type and season, and not specifically on venting. All four studies were field experiments, many treatments had uneven sample sizes and the venting device was often not consistent, even within the same study (syringe, fish hook, dive knife etc.). In the review paper two of these studies received a relative risk score of greater than one (Gitschlag and Renaud 1994; Render and Wilson 1996), indicating that, similarly to this study, venting had a positive effect on survival. In light of these findings, venting has been shown to clearly improve survival.

The other two studies had scores of less than one, suggesting that venting did not increase survival (Burns 2002; Render and Wilson 1996), but there may be several



explanations why their methodology might not have been ideal for studying venting as a means of improving survival from deep-water barotrauma. Render and Wilson (1994) only dealt with fish caught from 21 m of depth or less. It's possible that with a depth that shallow venting effects might be negligible. At greater depths, especially of 60 m or more that are common in many parts of the Gulf of Mexico, venting is likely far more important to survival. The lowest relative risk score among the red snapper studies was from Burns et al. (2002). Most tag-recapture data from this study was collected by volunteer anglers, so there was variability between venting styles, types of tools and experience. Burns et al. (2002) actually states that a major source of mortality was improperly vented fish from head boats (large vessels that can take dozens of recreational anglers), that may have vented the everted stomach and not the swim bladder. Additionally, sample size in the study was very uneven between vented and non-vented fish. They conclude that greater survival occurred within the non-vented groups, but the sample size differences, among other methodological issues, must be taken into consideration when evaluating these findings.

Burns (2004) was not included in Wilde's (2009) review, but conducted hyperbaric studies where all red snapper were vented and in contrast to my study found only 55% survival from 61 m. However, this study did not report sample sizes or water temperatures. Additionally, similar to my results, they did report that upon venting and release into the holding tank most of the red snapper remained upright on the bottom and behaved normally. While venting in the field is performed by laypersons, public outreach and education can improve the technique of the angling population. Venting may not be appropriate for all fish, but my results suggest that this determination should be made

individually for each species and based on the best research available. In a species that does not respond positively to venting, alternative barotrauma relief procedures should be explored.

### *Rapid recompression*

A recently developed alternative method in reducing the effects of barotraumas is rapid recompression. Results from this study show that rapidly recompressing red snapper to depth can be very successful in improving survival of released fish and is a viable solution to mitigate barotrauma symptoms. I also included a treatment of fish in this study where they were both vented and recompressed, and the results showed there was little difference in survival between vented and non-vented treatments within this release type. This study found that rapid recompression alone improves fish condition, making it unnecessary to also vent the fish. Venting is a more invasive procedure and there is a possibility of introducing infection (though none was seen in this study), so a fish that will be rapidly recompressed should not be vented as well. My results show that rapid recompression by itself is the best method of improving survival for released red snapper.

Experiments on other species prone to barotrauma found similar success with release at depth. A field study on yelloweye rockfish (*Sebastes ruberrimus*) released at depth with descender hooks showed a remarkable survival probability of 0.988 compared to those released at the surface 0.221 (Hochhalter and Reed 2011). Like red snapper, rockfish have major commercial and recreational fisheries and inhabit rocky reef habitats at similar depths (Hannah et al. 2008). Another study on several species of southern California rockfish found that rapid recompression significantly increased discard

survival and that time spent at the surface was the most significant predictor of immediate mortality (Jarvis and Lowe 2008).

The high survival rates from rapid recompression found in my study are encouraging in the development of effective barotrauma relief procedures, but there are other factors to consider in developing management practices. My laboratory study simulated the physiological return to depth. However, it excluded many factors that would be present in the field, including the actual device that would return the fish to its capture point. It is possible that stress associated with struggling against a hook as the fish moves up and down the water column and the amount of time spent at the surface while a recompression device is attached may counteract some the benefits of recompressing gasses within the swim bladder. However, an important benefit of this practice is returning fish to depths where they are less of a target to predators. Since fish in this study were confined to experimental chambers, it was not logistically possible to do any simulated predation for this component. However it is likely that rapid recompression would improve recovery (and predator evasion) upon release as well.

### *Predation*

In this study sublethal impairment due to barotrauma often resulted in failure to evade a simulated predator upon release, especially if a fish was not vented. Failed behavior BtR tests resulted in significantly higher scores in non-vented fish. It is very unlikely that a fish exhibiting these impaired symptoms in the laboratory could escape a predator in the wild. A major cause of discard mortality of reef fish is predation by animals such as dolphins, barracudas and sharks (Burns et al. 2004). Red snapper are fished heavily around artificial reefs during their short recreational season and tertiary

predators like dolphins likely associate these areas with easy prey (Burns et al. 2004; Powell and Wells 2011). Released fish with expanded air bladders have difficulty submerging, making them more susceptible to predation. In this laboratory environment with only simulated predation, some non-vented fish survived and their swim bladders slowly equilibrated over several hours. However, in the wild a fish floating at the surface for an hour or more would most likely have less chance of survival. For example, if the failure to escape a simulated predator was considered a proxy for mortality, then all of non-vented fish from 30 m would have been dead within five min, and 88% of 60 m fish would also have died. It may seem unusual that the greater depth had a lower mortality rate, but this number only represents the few fish that survived to five min at all (i.e., simulated predation was not done if a fish was already dead). While not all literature supports the use venting, if it allows a species to submerge to its preferred water depth, it may increase survival due to mortality they face from surface predators.

#### *Multiple decompression events*

Multiple decompression events in this study resulted in higher BtR scores and lower survival. The possibility of multiple catching events of the same fish in the wild is very possible due to the heavy fishing pressure during the recreational season, and tagging studies from ours and other research groups show fish are often captured multiple times (Burns et al. 2004; Patterson et al. 2002). Moreover, high site fidelity within this species also increases the likelihood of these recaptures (Schroepfer and Szedlmayer 2006). While overall BtR scores increased and survival decreased with multiple barotrauma events, the fish showed considerable individual variability in sublethal effects and survival. Mortality did not always occur after the same number of events in each

treatment, and some fish, particularly in the vented groups, survived all three events (up to five in preliminary trials). However, in all experimental treatments BtR scores increased with every additional decompression event. Thus, venting improved chances of survival during all decompression events, but multiple captures caused increased sublethal effects for all fish. However, in this experiment decompression events on the same fish occurred within a few days of each other, once the fish began eating again. In the wild a fish would be less likely to be captured and then caught again 2-3 d later. Additional time for recovery might improve sublethal effects of the next potential capture event. Capture from shallow depths (less than 30 m) might also help decrease the negative effects of multiple barotrauma events.

#### *Effects of depth*

Some BtR symptoms occurred more frequently than others and deeper depths were characterized by different response. In general, the deeper the capture depth, the more severe the BrR score. These results show a clear depth effect and a particular need for either venting or rapid recompression as fishing depth increases. The most common and easily recognizable sign of barotrauma was a distended abdomen; present in nearly all non-control fish. Exophthalmia was only observed in the 60 m treatment group and the large majority of intestinal protrusion was also from 60 m; suggesting these injuries are likely to manifest only with greater swim bladder expansion (Rummer and Bennett 2005). However, mortality and serious injuries such as stomach eversion and subcutaneous hemorrhaging were observed from 30 m. While ascending from 60 m represents a higher risk, there was not a linear increase in BtR score. Following Boyle's law, the change in swim bladder volume from a short ascent in shallow water (30 m to

the surface) is considerably greater than the change in volume that occurs when making the same change in depth but beginning in deeper water (60 m to 30 m) (Parker et al. 2006). For example, a swim bladder that was 1.5 mL at 60 m would enlarge to about 2.5 mL at 30 m, but would expand to 10 mL at the surface. However, sublethal effect scores were higher in fish brought up from 60 m than those from 30 m. Several other studies have also concluded that red snapper captured from deeper waters can be expected to have more frequent and more severe injuries as space decreases in the body cavity (Campbell et al. 2010a; Gitschlag and Renaud 1994; Rummer and Bennett 2005). Thus, fish caught from deeper depths are more likely to have severe barotrauma injuries, making it even more critical to either vent or rapidly recompress the fish to maximize the chance for survival.

#### *Immediate and long term survival*

All fish were monitored for at least three weeks and no delayed mortality from barotrauma occurred past 18 hours of the decompression event, and all fish resumed normal eating behavior within one or two d after the event. If fish survived the initial 18 hours after release, they showed no long term impairment from the experiment. There were two instances where fish died prior to three weeks, but these mortalities were due to fish having leapt from the tanks, and were not related to experiments. It has been suggested that the injuries incurred from decompression might affect feeding or other necessary life processes, and that delayed mortality might occur days to weeks after being captured (Rummer and Bennett 2005). These results did show any long term negative effects of decompression on mortality or eating behavior. Results from this study were similar to those found in previous field studies on survival of released red snapper

(Diamond and Campbell 2009; Gitschlag and Renaud 1994). These studies also concluded that red snapper do not suffer from a substantial amount of delayed mortality after release from barotrauma. Gitschlag and Renaud (1994) conducted a caged study where fish were monitored by scuba divers for 10-15 d. They reported that 90% of all deaths occurred during the first 24 hours and 95% occurred within 48 hours. Diamond and Campbell (2009), who performed similar research using caged fish and scuba divers to observe the effects of barotrauma after release. Similarly, they showed virtually all mortality occurred within the first 48 h. Thus, based on these findings and others barotrauma-related mortality seems to occur rapidly, and if the fish survives the initial 48 h, there is minimal risk of delayed mortality. This further demonstrates the value of either venting or rapid recompression to return the fish to depth to maximize survival.

### **Differences in laboratory and field conditions**

All laboratory studies have certain limitations, but they are extremely valuable because they allow the researcher to control all outside variables to produce clear results. In a laboratory study, a fish can be closely monitored after a decompression event and survival can be determined with certainty. None of the complications associated with open-water field work will confound a laboratory experiment. For example, field studies with cages remove the effects of predators and cannot be used long term because the fish's ability to catch prey is inhibited. In acoustic studies, where a released fish is tracked with an acoustic tag, it may not be possible to differentiate a mortality event from a lost tag. Mark and recapture studies can be done over long time periods but require large sample sizes, many participants, give limited information, and the fate of fish not

captured is unknown. However, some caution should be taken to interpret if laboratory conditions have any influence on results.

There are certain conditions that were not replicated in the laboratory environment that can affect fish survival, making the argument that survival here is under “ideal” conditions. For example, factors such as hooking trauma and temperature stress were not a factor in this research. Multiple studies, including unpublished acoustic data from our laboratory, have found that warmer sea surface temperatures during summer months significantly decrease survival of discarded red snapper (Campbell et al. 2010b; Diamond and Campbell 2009). During fish collections for this study it was difficult to keep fish alive to bring back to the laboratory during summer months, while survival was very high in cooler fall and spring collections. Temperature considerations are also important because the recreational red snapper season is currently restricted to June through August; which are the hottest months on the Gulf coast.

Additionally, housing wild red snapper in a laboratory environment may make the fish themselves different than an equal sized sample found in their natural habitat. All fish in this experiment had already undergone a potential barotrauma event at least once during their initial capture, and were survivors of hooking, handling, transport and captivity. All efforts were made to minimize any initial trauma, but less robust individuals died in the field during collection or at the AgriLife facility before the experiments. Despite these differences, the laboratory effectively mimicked most of the conditions encountered by red snapper captured by anglers. The fish themselves, however, were likely healthier and more resilient than their average wild counterparts (Campbell et al. 2010a). The important conclusion from this difference is that all findings



of sublethal effects and mortality in this study are likely conservative estimates, and that natural populations would likely have greater injuries and lower survival rates.

### **Management implications and conclusions**

The findings from this study indicate that venting or rapid recompression are both very viable methods of increasing survival of red snapper regulatory discards. Fisheries managers should encourage the use of either of these two techniques to aid in the recovery of this important fishery. However, there are several factors that should be considered when developing management practices. Proper venting tool use and technique are an essential part of making this procedure an effective management strategy. I have observed even “seasoned” anglers and scientists using incorrect venting techniques. Public outreach education into proper venting location and promotion of specially designed venting tools would likely improve the fate of vented and released regulatory discards. Sea Grant, a university based program managed by the National Oceanic and Atmospheric Administration, is already leading the way in this type of public education about venting. Florida Sea Grant specifically has a section of their website devoted to the practice, and has made brochures, YouTube videos and PowerPoint tutorials to spread information to the public about why venting is important and how to properly use the technique. A recommendation from this study is that other states should develop similar programs.

Overall, I recommend rapid recompression as the best method for improving survival, but in the field this technique may not be as practical as venting. Venting takes only a few seconds, often referred to as the “pop-and-drop” method. Putting a fish on a descender hook or other recompression device to return it to depth takes several minutes

and requires dedicated gear. This may not be practical under many circumstances or vessels. For example, in the recreational red snapper fishery, head boats take out hundreds of customers onboard. Deckhands spend considerable time de-hooking fishing and releasing regulatory discards. In this setting rapid recompression would nearly be unfeasible. A regulation requiring rapid recompression of discards would be difficult to enforce, and those who work in the head boat industry would almost certainly have objections. However, private boats with small parties could rapidly recompress the fish they released with little disruption of their experience. This action could also be used when red snapper are caught out of season. Thus, based on results of this study it is recommended that rapid recompression be used as preferred method of barotrauma relief in red snapper, but if this is not feasible, comparable results can be achieved by venting the fish.

This study opens up many questions for future research, including how barotrauma in red snapper might affect other trophic levels in artificial reef habitats. For example, fish in this study that survived decompression easily resumed eating floating pellets two to three days after release, though they might have more difficulty catching live prey. Future laboratory studies might evaluate red snapper ability to catch live prey after experiencing decompression. This study design would allow researchers to understand how red snapper prey species might be affected on artificial reefs with heavy fishing pressure. Additionally, field studies would aid in evaluating ecological impacts of barotrauma in this species. One design would be to compare the density and diversity of all species at artificial reefs experiencing heavy red snapper fishing pressure to artificial reefs closed to fishing. This could be accomplished using diver and remotely operated

vehicle surveys. Future research in these areas will be critical to gaining an ecological view of the impacts of barotrauma in red snapper.

Additionally, methods developed here may be a template for other researchers studying barotrauma in other fisheries. Barotrauma concerns impact several other highly valued commercial species such as red emperor (*Lutjanus sebae*), Chinook salmon (*Oncorhynchus tshawytscha*), Hawaiian pink snapper (*Pristipomoides filamentosus*), several rockfish (*Sebastes*) species, and small and largemouth bass (*Micropterus dolomieu* and *Micropterus salmoides*), (Brown et al. 2010; Brown et al. 2009; DeMartini et al. 1996; Gravel and Cooke 2008; Hannah et al. 2008; Lee 1992; Nguyen et al. 2009; Nichol and Chilton 2006; Stephenson et al. 2010). This study found venting and rapid recompression are excellent options for reducing barotrauma-related release mortality, though their efficacy will likely vary depending on the biological characteristics of each species. The experimental design described here could be used on other barotrauma-prone physoclistous fish to determine if these methods of increasing survival are viable for them. Understanding the impacts of barotrauma in red snapper provides information that will aid in improving the catch and release survival rates for other deep-water fisheries.

Red snapper hold a vital place in the Gulf of Mexico ecosystem as a high-level generalist predator and are also the most economically valued reef fish. My use of hyperbaric experimentation using red snapper was novel in examining how venting, rapid recompression and multiple barotraumas affect survival and recovery upon release. It is critically important to the management of deep-dwelling fish species to study the effects of barotrauma and how to increase survival rates of discards. These findings may revise

discard mortality estimates, resulting in more accurate stock assessments, and influence barotrauma relief guidelines. The last stock assessment estimated 60% survival of discarded fish in the western Gulf of Mexico. My results show that if fish are not vented there is only 17% survival after decompression from 60 m, and 67% survival from 30 m, but that venting can improve these rates. The data and results presented in this thesis research have vital significance to management strategies of this fishery, and are highly relevant to decisions being made in the very near future by the Gulf of Mexico Fisheries Council Management Council. The overall goal of this project was to determine methods to improve long term red snapper sustainability and also to provide insight into improving conservation of all species affected by barotrauma concerns. Research on this issue is imperative in highly regulated fisheries that employ catch-and-release fishing as a central management tool. This research will contribute to the body of information managers can use to develop strategies to recover red snapper populations and decide how best to balance the ecological and economic concerns associated with this important fishery.

**LITERATURE CITED**

- Brill, R., C. Magel, M. Davis, R. Hannah, and P. Rankin. 2008. Effects of rapid decompression and exposure to bright light on visual function in black rockfish (*Sebastes melanops*) and Pacific halibut (*Hippoglossus stenolepis*). *Fishery Bulletin* 106(4):427-437.
- Brown, I., W. Sumpton, M. McLennan, D. Mayer, M. Campbell, J. Kirkwood, A. Butcher, I. Halliday, A. Mapleston, D. Welch, G. A. Begg, and B. Sawynok. 2010. An improved technique for estimating short-term survival of released line-caught fish, and an application comparing barotrauma-relief methods in red emperor (*Lutjanus sebae* Cuvier 1816). *Journal of Experimental Marine Biology and Ecology*. 385: 1-7.
- Brown, R. S., T. Carlson, A. Welch, J. R. Stephenson, S. Abernethy, B. D. Ebberts, M. J. Langeslay, M. L. Ahmann, D. H. Feil, J. R. Skalski, and R. L. Townsend. 2009. Assessment of barotrauma from rapid decompression of depth-acclimated juvenile chinook salmon bearing radiotelemetry transmitters. *Transactions of the American Fisheries Society* 138(6):1285-1301.
- Burns, K., N. F. Parnell, and J. Raymond R. Wilson. 2004. Partitioning release mortality in the undersized red snapper bycatch: comparison of depth vs. hooking effects. *Mote Marine Laboratory Technical Report*. 932.
- Burns, K. M., C. C. Koenig, and F. C. Coleman. 2002. Evaluation of multiple factors involved in release mortality of undersized red grouper, gag, red snapper, and vermilion snapper. *Mote Marine Laboratory Technical Report*. 790.
- Campbell, M. D., R. Patino, J. Tolan, R. Strauss, and S. L. Diamond. 2010a. Sublethal effects of catch-and-release fishing: measuring capture stress, fish impairment, and predation risk using a condition index. *Ices Journal of Marine Science* 67(3):513-521.
- Campbell, M. D., J. Tolan, R. Strauss, and S. L. Diamond. 2010b. Relating angling-dependent fish impairment to immediate release mortality of red snapper (*Lutjanus campechanus*). *Fisheries Research* 106(1):64-70.
- Cowan, J. H. 2011. Red snapper in the Gulf of Mexico and U.S. south Atlantic: data, doubt and debate. *Fisheries* 36(7):319-331.

- Cowan, J. H., C. B. Grimes, W. F. Patterson III, C. J. Walters, A. C. Jones, W. J. Lindberg, D. J. Sheehy, W. E. Pine III, J. E. Powers, M. D. Campbell, K. C. Lindeman, S. L. Diamond, R. Hilborn, H. T. Gibson, K. A. Rose. 2011. Red snapper management in the Gulf of Mexico: science- or faith-based? *Reviews of Fish Biology and Fisheries*. 21:187-204
- Davis, M. W., and B. L. Olla. 2001. Stress and delayed mortality induced in Pacific halibut by exposure to hooking, net towing, elevated seawater temperature and air: implications for management of bycatch. *North American Journal of Fisheries Management* 21(4):725-732.
- Davis, M. W., and M. L. Ottmar. 2006. Wounding and reflex impairment may be predictors for mortality in discarded or escaped fish. *Fisheries Research* 82(1-3):1-6.
- DeMartini, E. E., F. A. Parrish, and D. M. Ellis. 1996. Barotrauma-associated regurgitation of food: implications for diet studies of Hawaiian pink snapper, *Pristipomoides filamentosus* (family Lutjanidae). *Fishery Bulletin* 94(2):250-256.
- Derr, R. 2000. Performing exact regression regression with the SAS system. SUGI Proceedings, SAS Institute Inc, Cary, NC.
- Diamond, S. L., and M. D. Campbell. 2009. Linking 'sink or swim' indicators to delayed mortality in red snapper by using a condition index. *Marine and Coastal Fisheries: Dynamics, Management, and Ecosystem Science* 1(1):107-120.
- Dowling, C. E., K. C. Hall, and M. K. Broadhurst. 2010. Immediate fate of angled-and-released Australian bass *Macquaria novemaculeata*. *Hydrobiologia* 641:145-147.
- Gallaway, B. J., S. T. Szedlmayer, and W. J. Gazey. 2009. A life history review for red snapper in the Gulf of Mexico with an evaluation of the importance of offshore petroleum platforms and other artificial reefs. *Reviews in Fisheries Science* 17(1):48-67.
- Gitschlag, G. R., and M. L. Renaud. 1994. Field experiments on survival rates of caged and released red snapper. *North American Journal of Fisheries Management* 14(1):131-136.
- GMFMC. 2009. Stock assessment of red snapper in the Gulf of Mexico SEDAR update assessment. Gulf of Mexico Fisheries Management Council, Miami, FL.

- Gravel, M. A., and S. J. Cooke. 2008. Severity of barotrauma influences the physiological status, postrelease behavior, and fate of tournament-caught smallmouth bass. *North American Journal of Fisheries Management* 28(2):607-617.
- Hannah, R. W., S. J. Parker, and K. M. Matteson. 2008. Escaping the surface: the effect of capture depth on submergence success of surface-released Pacific rockfish. *North American Journal of Fisheries Management* 28(3):694-700.
- Harrington, J. M., R. A. Myers, and A. A. Rosenberg. 2005. Wasted fishery resources: discarded by-catch in the USA. *Fish and Fisheries* 6(4):350-361.
- Hirji, K. F., C. R. Mehta, and N. R. Patel. 1987. Computing distributions for exact logistic-regression. *Journal of the American Statistical Association* 82(400):1110-1117.
- Hochhalter, S. J., and D. J. Reed. 2011. The effectiveness of deepwater release at improving the survival of discarded yelloweye rockfish. *North American Journal of Fisheries Management* 31(5):852-860.
- James, J. T., G. W. Stunz, and D. A. McKee. 2007. Catch-and-release mortality of spotted seatrout in Texas: effects of tournaments, seasonality, and anatomical hooking location. *North American Journal of Fisheries Management* 27(3):900-907.
- Jarvis, E. T., and C. G. Lowe. 2008. The effects of barotrauma on the catch-and-release survival of southern California nearshore and shelf rockfish (*Scorpaenidae*, *Sebastes* spp.). *Canadian Journal of Fisheries and Aquatic Sciences* 65(7):1286-1296.
- Lee, D. P. 1992. Gas bladder deflation of depressurized largemouth bass. *North American Journal of Fisheries Management* 12:662-664.
- Manooch, C. S., J. C. Potts, D. S. Vaughan, and M. L. Burton. 1998. Population assessment of the red snapper from the southeastern United States. *Fisheries Research* 38(1):19-32.
- Milazzo, M. J. 2012. Progress and problems in US marine fisheries rebuilding plans. *Reviews in Fish Biology and Fisheries* 22(1):273-296.

- Nguyen, V., M. A. Gravel, A. Mapleston, K. C. Hanson, and S. J. Cooke. 2009. The post-release behaviour and fate of tournament-caught smallmouth bass after 'fizzing' to alleviate distended swim bladders. *Fisheries Research (Amsterdam)* 96(2-3):313-318.
- Nichol, D. G., and E. A. Chilton. 2006. Recuperation and behaviour of Pacific cod after barotrauma. *Ices Journal of Marine Science* 63(1):83-94.
- NMFS. 2012. Final rule- Gulf of Mexico red snapper quota increases and recreational season. *Southeast Fishery Bulletin*. National Marine Fisheries Service. St. Petersburg, FL
- Parker, S. J., H. I. McElderry, P. S. Rankin, and R. W. Hannah. 2006. Buoyancy regulation and barotrauma in two species of nearshore rockfish. *Transactions of the American Fisheries Society* 135(5):1213-1223.
- Patterson, W., W. Ingram, S. R. L., and J. H. Cowan. 2002. Indirect estimation of red snapper (*Lutjanus campechanus*) and gray trigger fish (*Balistes caprisucs*) release mortality. *Proceedings of the Gulf and Caribbean Fisheries Institute* 53.
- Patterson, W. F., III, J. H. Cowan, Jr., C. A. Wilson, and R. L. Shipp. 2001. Age and growth of red snapper, *Lutjanus campechanus*, from an artificial reef area off Alabama in the northern Gulf of Mexico. *Fishery Bulletin* 99(4):617-627.
- Pollock, K. H., and W. E. Pine. 2007. The design and analysis of field studies to estimate catch-and-release mortality. *Fisheries Management and Ecology* 14(2):123-130.
- Pope, K. L., and G. R. Wilde. 2004. Effect of catch-and-release angling on growth of largemouth bass, *Micropterus salmoides*. *Fisheries Management and Ecology* 11(1):39-44.
- Powell, J. R., and R. S. Wells. 2011. Recreational fishing depredation and associated behaviors involving common bottlenose dolphins (*Tursiops truncatus*) in Sarasota Bay, Florida. *Marine Mammal Science* 27(1):111-129.
- Pribyl, A. L., C. B. Schreck, M. L. Kent, and S. J. Parker. 2009. The differential response to decompression in three species of nearshore Pacific rockfish. *North American Journal of Fisheries Management* 29(5):1479-1486.
- Render, J., and C. Wilson. 1996. Effects of gas bladder deflation on mortality of hook-and-line caught and released red snapper: implications for management.



- International Center for Living Aquatic Resources Management Conference (ICLARM) Proceedings, Manila, Philippines. 244-253.
- Render, J. H., and C. A. Wilson. 1994. Hook-and-line mortality of caught and released red snapper around oil and gas platform structural habitat. *Bulletin of Marine Science* 55(2-3):1106-1111.
- Rummer, J. L. 2007. Factors affecting catch and release (CAR) mortality in fish: insight into CAR mortality in red snapper and the influence of catastrophic decompression. *American Fisheries Society Symposium* 60:113-132
- Rummer, J. L., and W. A. Bennett. 2005. Physiological effects of swim bladder overexpansion and catastrophic decompression on red snapper. *Transactions of the American Fisheries Society* 134(6):1457-1470.
- Schmidt-Nielson, K. 1997. *Animal physiology: adaptation and environment*, 5th edition. Cambridge University Press, Cambridge, UK.
- Schroepfer, R. L., and S. T. Szedlmayer. 2006. Estimates of residence and site fidelity for red snapper *Lutjanus campechanus* on artificial reefs in the northeastern Gulf of Mexico. *Bulletin of Marine Science* 78(1):93-101.
- SEDAR. 2005. Stock assessment report of SEDAR 7: Gulf of Mexico red snapper. Southeast Data, Assessment and Review, Charleston, SC.
- Stephenson, J. R., A. J. Gingerich, R. S. Brown, B. D. Pflugrath, Z. Q. Deng, T. J. Carlson, M. J. Langeslay, M. L. Ahmann, R. L. Johnson, and A. G. Seaburg. 2010. Assessing barotrauma in neutrally and negatively buoyant juvenile salmonids exposed to simulated hydro-turbine passage using a mobile aquatic barotrauma laboratory. *Fisheries Research* 106(3):271-278.
- Wells, R. J. D., J. H. Cowan, and B. Fry. 2008. Feeding ecology of red snapper *Lutjanus campechanus* in the northern Gulf of Mexico. *Marine Ecology Progress Series* 361:213-225.
- Wilde, G. R. 2009. Does Venting Promote Survival of Released Fish? *Fisheries* 34(1):20-28.
- Wilson, R. R., and K. L. Smith. 1985. Live capture, maintenance and partial decompression of a deep-sea grandier fish (*Coryphaenoides acrolepsis*) in a

hyperbaric trap-aquarium. Deep-Sea Research Part a-Oceanographic Research  
Papers 32(12):1571-1582.